

Passed ISO9001 quality management system Certification and EU CE certification



VEIKONG

**Pragmaticism
Innovation
Unity
Endeavor**



202307 version

ShenZhen VEIKONG Electric CO.,Ltd.

+86 0755 89587650

www.veikong.com/ www.veikong-electric.com



4F, Building 5, Dongluyang Industrial ,Park, No. 4, Tengfeng 4th Road,
Fuyong Phoenix Third, Industrial Zone, Baoan District, Shenzhen



**VFD580 VFD586 Series
High End Variable Frequency Drive**

Company profile

Shenzhen Veikong Electric CO.,Ltd. a high-tech enterprise which has been specializing in researching, manufacturing and trading high, medium and low voltage inverter as well as bypass contactor soft starter, providing our clients with integrated system solutions. We have professional R&D and devoted management team with more than 20 years' experience of theoretical research, product development and quality management. Veikong is also one of the first independent AC drives company in China. We adopt SPWM, sensorless vector control and vector and torque control technology in our VFD series, which has reached the international advanced standard. The products can directly replace and be equivalent of Europe and the United States, Japan and other brands, providing customers with a powerful technical support. We have achieved popularity and qualification in VFD and soft starter industry. Quality is the life of enterprise. Veikong drives keeps following ISO9001 standard to manage and supervise quality. Our products have passed CE certification and other technical approval. To better achieve customer requirements and market needs, Veikong drives keeps on upgrading new technologies and new products with more than 10% of our income invest. The customer is the source of enterprise. We are honored to put top priority on customers' requirements as well as achieving their requirements. Our products have been widely used in petroleum, chemical, melting, hoisting, electric power, building materials, water supply, plastics, textiles, printing, packing and other industries to create value for customers. Veikong, your trusted supplier in China!!!

-  **Company values**
Diligence, Innovation, Effort, Integrity;
-  **Business philosophy**
Mutual value, win-win cooperation,
-  **Vision**
Become a world-class provider of drive control products and solutions;



Qualification certifications



VFD580 Series High End Variable Frequency Drive

VFD580 drive adopts leading design methods, showing excellent performance like scalability, reliability, electromagnetic compatibility and other aspects, mainly targeting occasions with high demands product with comprehensive performance.

Rich communication interface

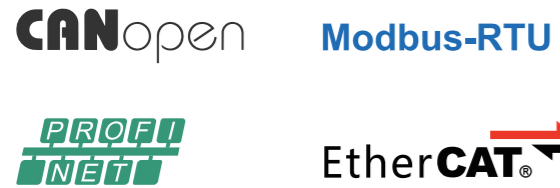

Compatible with various encoders

- . Incremental HTL/TTL
- . Resolver
- . SinCos interface encoder
- . Smart-Abs interface encoder
- . SSI / BISS interface encoder



Compatible with multiple motors

Asynchronous motor, servo motor, synchronous motor;



Protection from all sides

- . Three-phase current detection
- . Short circuit protection to ground
- . Charging circuit abnormal protection
- . Brake resistor short circuit protection

Security function

- . STO (Safe Torque Off) function, compliant with IEC 62061-SIL3.

Hardware configuration

- . From frame size C, the built-in DC reactor is standard
- . Standard motor temperature sensor interface, support PT100, PT1000, KTY84, PTC and other input
- . Standard one encoder interface, support NPN type HTL input, or complementary type TTL input;
- . Fully independent air duct design, no derating at 50°C ambient temperature

Powerful performance

- . Unique online identification technology to adapt to various complex applications
- . Strong speed-up ability of weak magnetic field, higher loop bandwidth;
- . Frequency conversion servo integrated design, integrated senseless vector and closed-loop vector control, supports three operating modes of torque/speed/position.

User friendly

- . All weak current circuits adopt plug-in design, which is convenient for installation and maintenance;



- . MTSOP1 colorful LCD display can support multiple languages and graphical operation, bringing a new user experience.

Excellent performance

High speed accuracy and wide speed range

- Steady speed accuracy: $\pm 0.5\%$ (SVC), $\pm 0.02\%$ (VC);
- Speed range: 1:200 (SVC), 1:1000 (VC);
- Heavy load overload capability: 110% rated current for long-term stable operation;
- 150% rated current for 1 minute 180% rated current 10s.

SVC 100Hz step response
(three-phase asynchronous motor with F N=50Hz)

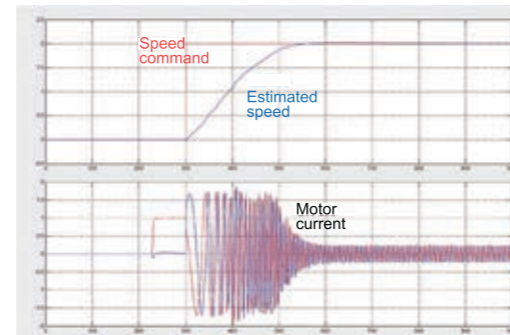

Powerful synchronous motor with weak magnetic performance

- Excellent weak magnetic control algorithm that supports deep weak magnetic control of permanent magnetic synchronous motors.
- Stable, accurate and fast current loop adjustment;
- The operating current of the same load in the field weakening area is smaller.

FOC 100Hz step response
(Permanent magnetic synchronous motor with F N=50Hz)

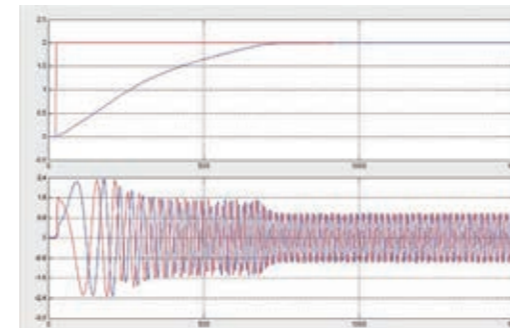

Dynamic fast response

- In SVC mode, the acceleration and deceleration time can be set arbitrarily (even 0.0s). The inverter runs stably without alarming, esp in some occasions requiring quick response

0.0s acceleration and deceleration time
fast forward and reverse

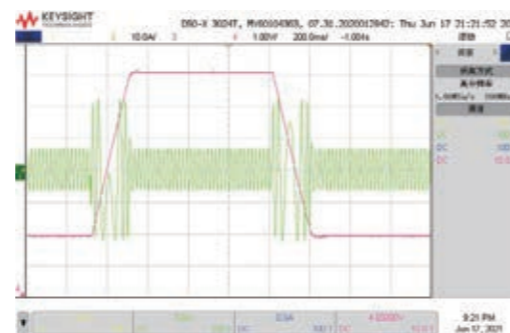

Powerful motor adaptability

- The motor self-tuning is convenient and accurate, and supports a variety of motors:
 - AC asynchronous motor: standard type, high frequency type, various non-standard types;
 - Permanent magnetic synchronous motor: surface mount type, embedded type, high frequency type, direct drive type, suspension type;
- Support online identification of multiple key parameters, without fear of motor temperature changes and performance degradation after a long service life



Multifunctional and user-friendly

Built-in spindle control function

- Shorter orientation time and high positioning accuracy;
- Support full closed loop position, more accurate positioning;
- Closed-loop vector VFD580 up to 1200Hz, VFD586 up to 2500Hz.

Schematic diagram of spindle positioning

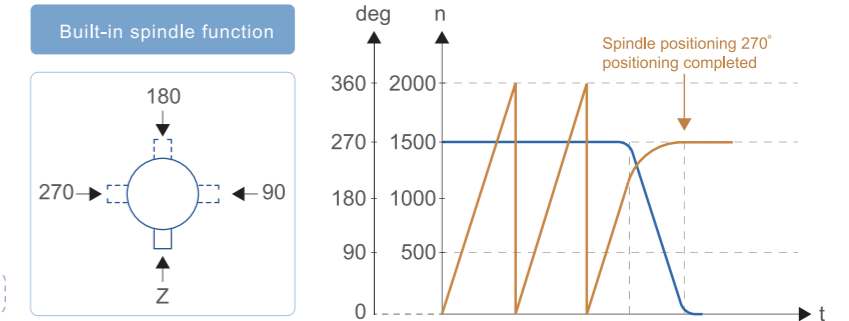

Rich expansion function

- CCAN and Modbus can be used in parallel. Enabling the internal networking mode of CAN makes it easy to achieve torque synchronization, speed synchronization, and position synchronization between multiple drivers.
- MT586 supports EtherCAT real-time communication.

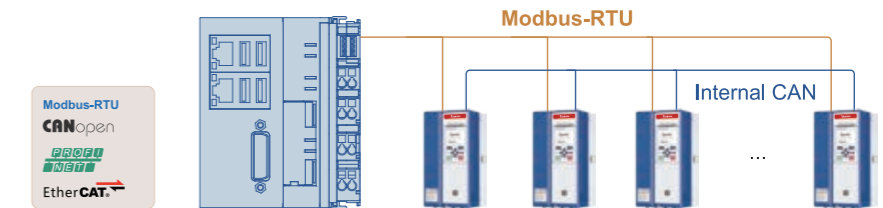

Built-in electronic cam function

- VFD586 has a built-in electronic cam function, which can reduce the cost budget of the control system for users.

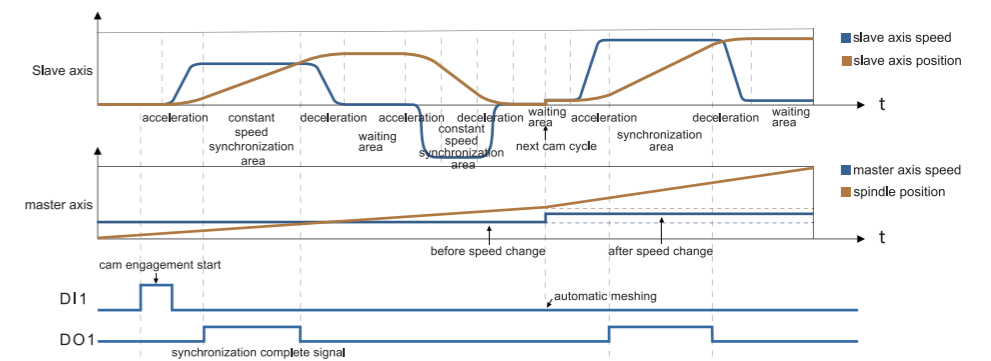

Intelligent operation panel

- The industry's first 2.3-inch TFT color operation panel;
- Streamlined user experience;
- Intelligent operating system, parameter batch processing, macro parameter import/export, file management, equipment upgrade, curve diagnosis and many other advanced functions;
- Five languages: Chinese, English, Russian, Turkish, Spanish, more languages are under development;



K	C	20:49:37	0.00Hz	I	C	21:10:52	0.00Hz	K	C	21:04:32	0.00Hz
PID final set v...	0.0%	Running frequen...	0.00Hz	Output voltage	0.0V	Bus voltage...	565V	Output current...	0.0A	Bus voltage...	565V
PID final feedb...	0.0%	Output torque	0.0%	Heat sink temper...	29.2	Heat sink temper...	29.2	Heat sink temper...	29.2	Heat sink temper...	29.2
PID final outpu...	0.0%	Heat sink temper...	29.2	Heat sink temper...	29.2	Heat sink temper...	29.2	Heat sink temper...	29.2	Heat sink temper...	29.2
PID digital setti...	0.0	Heat sink temper...	29.2	Heat sink temper...	29.2	Heat sink temper...	29.2	Heat sink temper...	29.2	Heat sink temper...	29.2
Menu <14>	Select	Menu <11>	Select	Menu <11>	Select	Menu <11>	Select	Menu <11>	Select	Menu <11>	Select

Multifunctional and user-friendly

Multiple practical functions

• Process PID

Multiple options for input and feedback sources are provided, including features such as feedback loss detection, output compensation, and parameter switching.

• Multi-step program operation

The 16-speed program can fulfill various flexible process requirements with multiple looping modes.

• Software exchange motor phase sequence

Both open-loop control and closed-loop vector control can switch the motor phase sequence with one click of a software, avoiding motor rewiring.

• Two groups of motor parameters can be switched

Support parameter switching of two groups of motors, use DI terminal or modify parameters to change the matching motor, realize one-to-two application.

• Non-stop with little faults

For most non-lethal faults, multiple response levels can be set for fault handling, such as continuing operation, emergency shutdown, stopping according to the set shutdown method, and free-stop, to minimize the impact on equipment operation.

• Parameter backup and restore

A copy of all current parameters can be saved to the built-in EEPROM backup area, which can be recalled from the memory when recovery is required.

Powerful internal logic

- Built-in up to 4 sets of delay units, a wide variety of input sources, the output can be used as a variety of other built-in module inputs.
- Built-in up to 4 sets of comparator units, any input, multiple comparison functions, the output can be used as a variety of other Built-in module inputs.
- Built-in up to 4 sets of logic units, arbitrary inputs, multiple logic operations, and outputs can be used as inputs for various other Built-in modules.
- The above modules can be used alone or in combination to achieve complex internal logic functions to meet various applications, saving peripheral equipment and wiring.

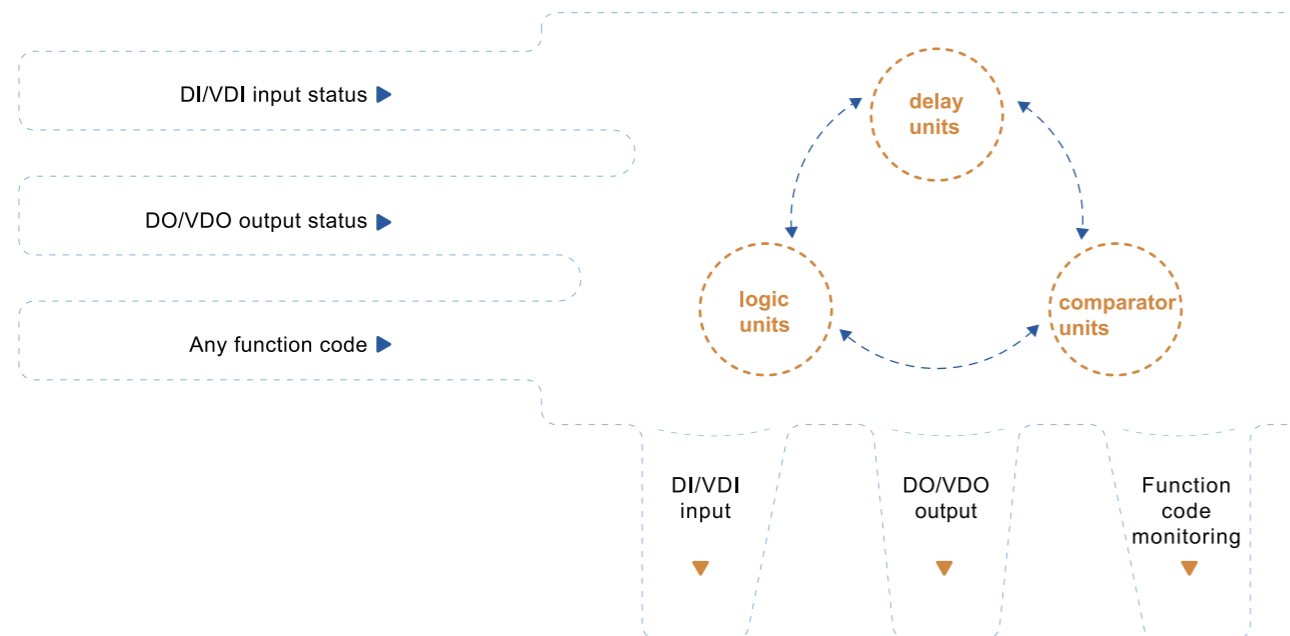

Powerful debugging software

- Support online oscilloscope function.
- Support parameter backup and download.
- Support function parameter modification.
- Support inverter software online upgrade.

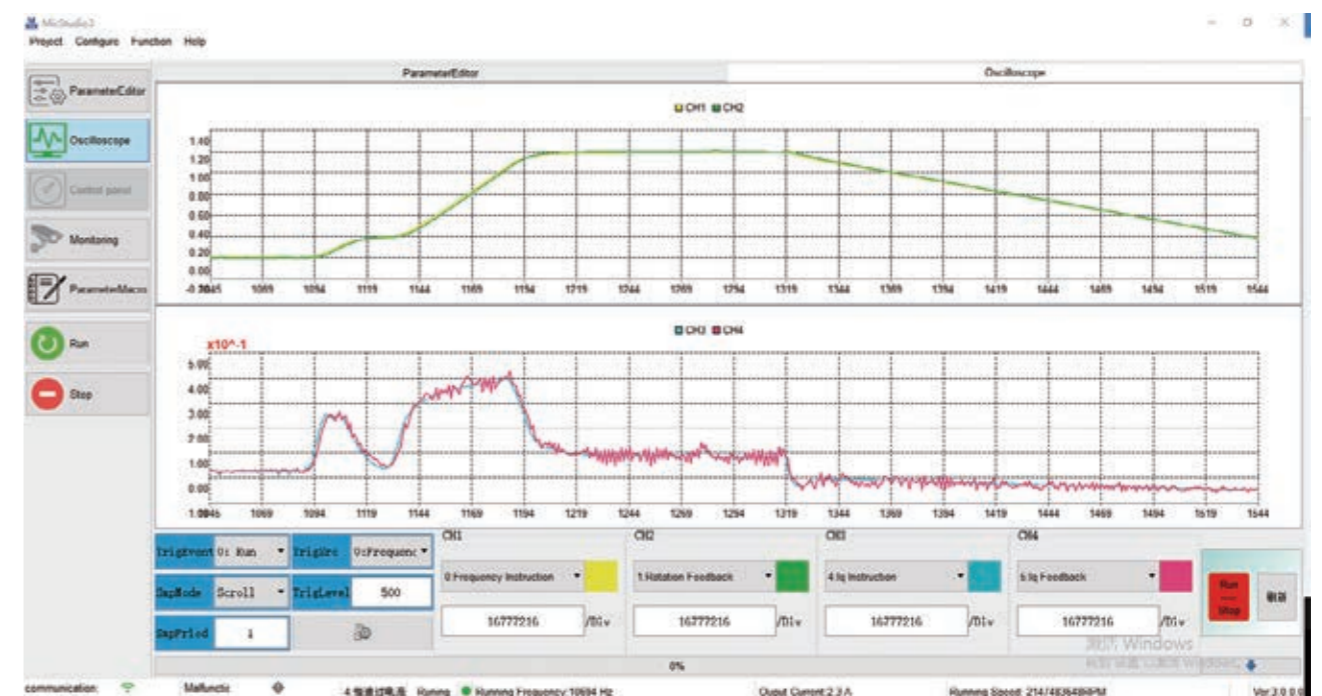
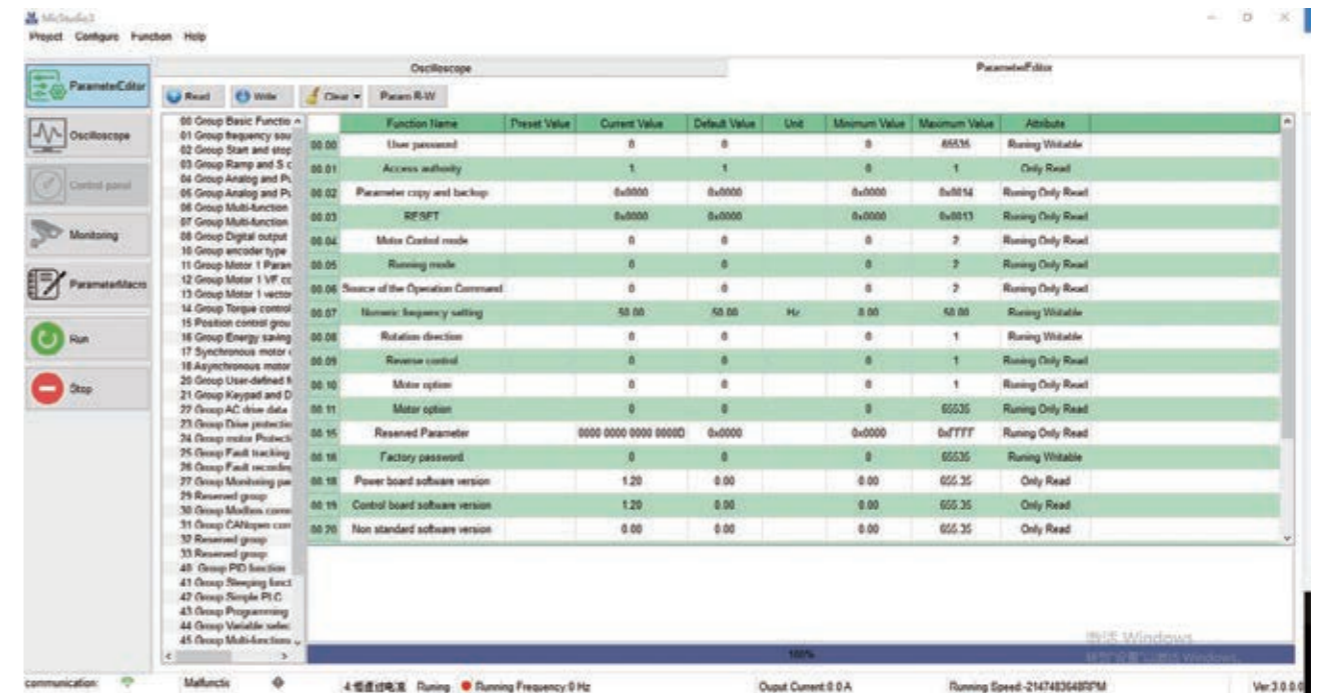

High reliability

High standard temperature-resistant design

- Wide tooth surface design reduces the risk of clogging in harsh environments;
- Large thermal design margin, no derating at 50°C ambient temperature;
- It can effectively deal with the characteristics of high ambient temperature and high cotton wool in the textile industry.

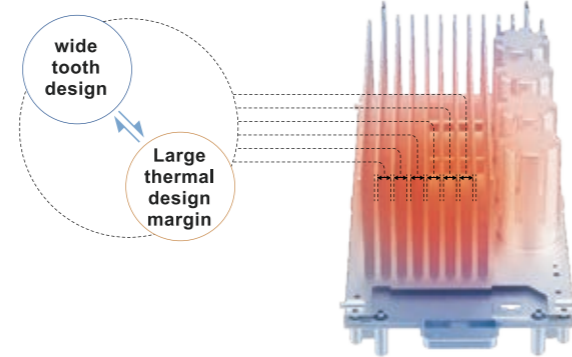

Perfect protection system

- The whole series has output-to-ground short-circuit protection, over-current protection, driver overload protection, motor overload protection, driver over-temperature protection, optional PT100 / PT1000 / KTY84 motor over-temperature protection, etc.;
- According to the type of failure, it can be set to free stop for failure, decelerate stop for failure, and continue to run for failure, which brings convenience to on-site handling of emergency situations.

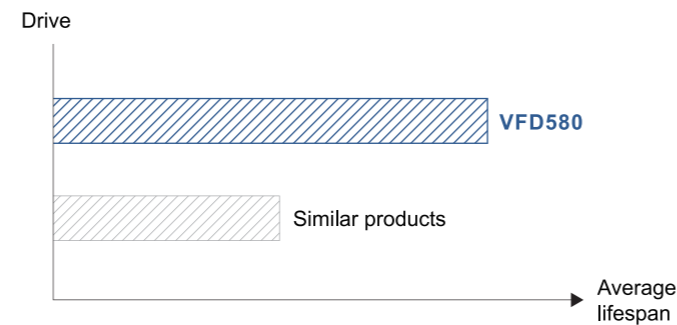

Independent duct design

- Independent air duct design, effectively preventing dust entering inverter, causing short-circuit and other faults and improving reliability.
- For environments with high oil pollution and dust, it can significantly increase the Mean Time Between Failures (MTBF). Support through-wall installation.

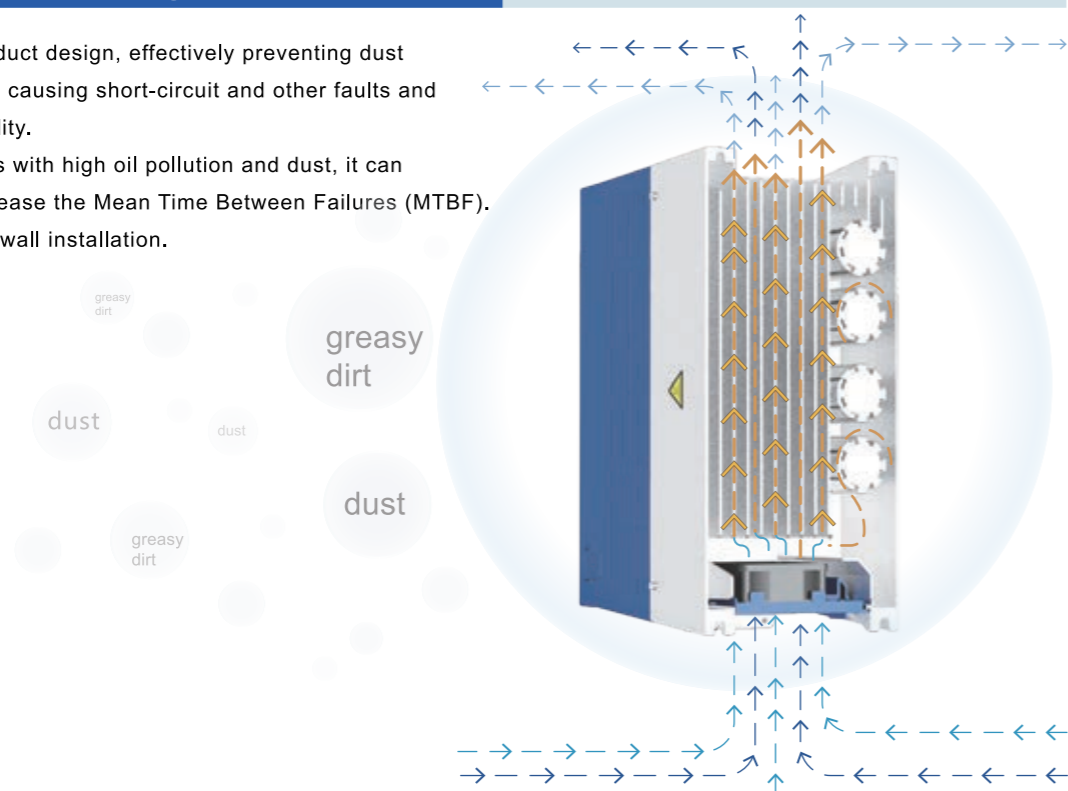

2

Selection specifications

Model description

VFD580 - 5R5 - T 4 B - 0 0 0

1 2 3 4 5 6 7 8

1 Product series code	
VFD580 :	Standard type
VFD586 :	EtherCAT bus type

3 Power phase	
T :	Three-phase input
S :	Single-phase input

5 Braking unit	
B :	With built-in brake unit
None :	Without built-in brake unit

6 Operational panel	
0 :	No operation panel
1 :	LED operation panel (MTBOP1)
2 :	Dual-line display LED operation panel (MTBOP2)
3 :	LCD operation panel (MTSOP1)

8 SLOT2 extension card port 2	
0 :	No communication card
1 :	CAN+RS485 (MT580-COMM-485)
2 :	RS485+IO expansion (MT580-IOEX1)
3 :	ProfiNet (MT580-COMM-PN)

2 Power models	
2R2	refers the power is 2.2kW
5R5	refers the power is 5.5kW
011	refers the power is 11kW

4 Power range	
2:	220V
4:	400V
6:	690V

7 SLOT 1 extension card port 1	
0 :	No encoder interface card
1 :	ABZ incremental encoder card with frequency division (MT580-PG-ABZ2)
2 :	ABZ fully closed-loop encoder card with frequency division (MT580-PG-ABZD2)
3 :	ABZUVW encoder card with frequency division (MT580-PG-ABZUVW2)
4 :	Resolver interface card (MT580-PG-RT1)
5 :	
6 :	Sin-cos encoder card with frequency division (MT580-PG-SIN2)
7 :	Tamagawa protocol absolute encoder card with frequency division (MT580-PG-ABS2)
8 :	SSI/BISS interface encoder (VFD586 only)

Series description

Model	Rated output current	Applicable motor	Size	Brake unit
Three phase : 400V				
VFD580/586-2R2-T4B	5.6A	2.2KW	SIZE A	Standard built-in
VFD580/586-4R0-T4B	9.4A	4.0KW		
VFD580/586-5R5-T4B	13.0A	5.5KW		
VFD580/586-7R5-T4B	17.0A	7.5KW	SIZE B	
VFD580/586-011-T4B	25.0A	11KW		
VFD580/586-015-T4B	32.0A	15KW	SIZE C	
VFD580/586-018-T4B	37.0A	18.5KW		
VFD580/586-022-T4B	45.0A	22KW		
VFD580/586-030-T4B	60.0A	30KW	SIZE D	
VFD580/586-037-T4B	75.0A	37KW		
VFD580/586-045-T4 (B)	90.0A	45KW	SIZE E	Optional built-in
VFD580/586-055-T4 (B)	110.0A	55KW		
VFD580/586-075-T4 (B)	152.0A	75KW	SIZE F	Optional built-in
VFD580/586-090-T4 (B)	176.0A	90KW		
VFD580/586-110-T4	210.0A	110KW	SIZE G	Circumscribed
VFD580/586-132-T4	253.0A	132KW		
VFD580/586-160-T4	304.0A	160KW	SIZE H	
VFD580/586-200-T4	380.0A	200KW	SIZE I	
VFD580/586-220-T4	426.0A	220KW		
VFD580/586-250-T4	465.0A	250KW		
VFD580/586-280-T4	520.0A	280KW	SIZE J	
VFD580/586-315-T4	585.0A	315KW		

Model	Rated output current	Applicable motor	Size	Brake unit
Single phase/Three phase : 220V				
VFD580/586-0R7-S2B (T2B)	5.6A	0.75KW	SIZE A	Standard built-in
VFD580/586-1R5-S2B (T2B)	8.0A	1.5KW		
VFD580/586-2R2-S2B (T2B)	10.6A	2.2KW		
VFD580/586-4R0-S2B (T2B)	17.0A	4.0KW	SIZE B	
VFD580/586-5R5-S2B (T2B)	25.0A	5.5KW		
VFD580/586-7R5-S2B (T2B)	32.0A	7.5KW	SIZE C	
VFD580/586-011-S2B (T2B)	45.0A	11KW		
VFD580/586-015-S2B (T2B)	60.0A	15KW		
VFD580/586-018-S2B (T2B)	75.0A	18.5KW	SIZE D	

Note: S2B represents single-phase 220V; T2B represents three-phase 220V.

Technical specifications

Item		Specification
Input	Input Voltage	1 phase/3phase 220V : 200V ~ 240V 3 phase 380V-480V : 380V ~ 480V
	Allowed Voltage fluctuation range	-15% ~ 10%
	Input frequency	50Hz / 60Hz, fluctuation less than 5%
	Input filter	SIZE C and above built-in DC reactor
Output	Output Voltage	3phase : 0 ~ input voltage
	Overload capacity	150% rated output current for 60 seconds; 180% rated output current for 10 seconds; 200% rated output current for 2.0 seconds
Control	Control mode	V/f control Sensorless flux vector control without PG card (SVC) Sensor speed flux vector control with PG card (VC)
	Operating mode	Speed control, torque control (SVC and VC), position servo
	Speed range	1:100 (V/f) 1:200 (SVC) 1:1000 (VC)
	Speed control accuracy	±0.5% (V/f) ±0.2% (SVC) ±0.01% (VC)
	Frequency range	Standard : 0.00 ~ 600.00Hz High frequency : 0.0 ~ 1200.0Hz (MT580)、0.0 ~ 2500.0Hz(MT586)
	Input frequency resolution	Digital setting: 0.01 Hz or 0.01% Analog setting: maximum frequency x 0.025%
	Startup torque	150%/0.5Hz (V/f) 180%/0.25Hz (SVC) 180%/0Hz (VC)
	Torque control accuracy	SVC: 8% within 5Hz, 5% above 5Hz VC: 3.0%
	Frequency giving ramp	Support linear and S curve acceleration and deceleration; 4 groups of acceleration and deceleration time, setting range 0.00s ~ 60000s
	Position control	Position command supports internal position, pulse position input, CANopen position command, EtherCAT position command (VFD586); supports position fully closed loop mode
	DC bus voltage control	VdcMax Control: Limit the amount of power generated by the motor by adjusting the output frequency to avoid over-voltage trip; VdcMin control: Control the power consumption of the motor by adjusting the output frequency, to avoid jump undervoltage fault
	Carrier frequency	1kHz ~ 16kHz(Varies depending on the type)
	Startup method	Direct start (can be superimposed DC brake); speed tracking start
	Stop method	Deceleration stop (can be superimposed DC braking); free to stop
Featured functions	Built-in delay unit, comparator unit and logic unit, etc., two groups of motor parameter switching, software switching output phase sequence, spindle orientation, online identification of motor parameters	

VFD580 control panel

Function	Keypad	The following three control panels can be configured: digital keyboard (MTBOP1); dual-display keyboard (MTBOP2); LCD keyboard (MTSOP1)
	Communication	SLOT2 expansion: MODBUS-RTU communication; CAN-Open communication; ProfiNet communication; EtherCAT communication (VFD586)
	Encoder interface	Standard: incremental encoder interface, differential or open-collector signal input; differential maximum input 500KHz, open-collector maximum input 100KHz; SLOT1 expansion: incremental encoder; resolver; sine-cosine encoder; Tamagawa Protocol absolute encoder; SSI/BISS interface encoder (VFD586)
	Input terminals	Standard: . 7 digital input terminals, one of which supports high-speed pulse input up to 50kHz; . 3 analog input terminals, one supports -10V ~ 10V input, two supports 0 ~ 10V voltage input or 0 ~ 20mA Current input; (VFD586 2 analog inputs, One channel supports -10-10V, and one channel supports 0-10 or 0-20mA options) . 1 motor temperature detection, support PT100, PT1000, KTY84-130 three kinds of thermistor input; SLOT2 expansion: 2 DI digital input terminals (MT580-IOEX1)
	Output terminals	Standard: . 2 digital output terminals; 1 of which is a high-speed pulse output terminal (open collector type), supporting square wave signal output from 0 to 50kHz; . 2 relay output terminals; . 2 analog output terminals, 1 Only supports 0 ~ 10V voltage output, one supports 0 ~ 20mA current output or 0 ~ 10V voltage output; (VFD586 1 analog output ,Supports 0-10V or 0-20mA options) SLOT2 expansion: 2 digital output terminals (MT580-IOEX1)
Protection	For the protection function, refer to Chapter 6 "Fault Diagnosis and Countermeasures" of the hardware manual (data number 22016001)	
Environment	Installation location	Indoor, no direct sunlight, dust, corrosive gas, combustible gas, oil smoke, vapor, drip or salt.
	Altitude	0 to 3000 meters. Above 1000 meters, reduction in use is required, with a decrease in rated output current of 1% for every 100 meters increase in altitude.
	Ambient temperature	-10°C ~ +50°C
	Humidity	Less than 95%RH, without condensing
	Vibration	Less than 5.9 m/s ² (0.6 g)
Installation	Storage temperature	-20°C ~ +60°C
	Installation	Wall-mounted, floor-standing electric control cabinet through-the-wall (requires optional accessories, see "7.2 Optional accessories for through-wall installation")
	Protection level	IP21
	Cooling method	Forced air cooling
	Grid System	TT/TN/IT (For IT grid system, VDR and EMC screws must be removed to disconnect from ground)



Definition of VFD580 control circuit terminals

Type	Terminal symbol	Terminal Name	Terminal function description
Analog input	VREF	Analog input reference voltage	VREF can choose 10V or 15V, switch between 10V and 15V of VREF through the "VREF" toggle switch, the factory default is 10V 10V±3%, 10V±3% , 15V±3% The maximum output current is 30mA, that is, the recommended external potentiometer resistance range: 1KΩ ~ 51KΩ
	GND	Analog input ground	Internally isolated from COM, 0V
	AI1	Analog input 1	Only input voltage:-10V~10V : Impedance 20KΩ
	AI2	Analog input 2	Input voltage:0~10V : Impedance 20KΩ , Maximum input voltage I Input current:0~20mA : Impedance 500Ω , Maximum input current Through the jumper switch AI2 0 ~ 10V and 0 ~ 20mA analog input switch, the factory default voltage input.
Analog output	AO1	Analog output 1	Output 0 ~ 10V: Impedance ≥10KΩ
	AO2	Analog output 2	Output voltage:0~10V : Impedance ≥10KΩ Output current:0~20mA : Impedance 200Ω~500Ω Through the jumper switch AO2 0 ~ 10V and 0 ~ 20mA analog output switching, the factory default voltage output.
	GND	Analog ground	Internal isolation from COM and 0V
Switch input	+24V	+24V current	24V ± 10%, internally isolated from GND and 0V Maximum output current : 200mA To provide 24V power supply, generally used as a digital input and output terminal power supply and external sensor power. When the "24V/PLC" toggle switch is ON, +24V and PLC are connected
	PLC	Digital input terminal common	The factory default setting is connected PLC with +24V terminal for on-off input high and low level switch When using the external power input, it will disconnect the connector slip of PLC with the +24V
	COM	+24V ground	Internal isolation from GND and 0V
	DI1 ~ DI4 /DI6 ~ DI7	Digital input terminal 1-4 or 6-7	Optocoupler isolation, compatible with bipolar input Frequency range : 0~200Hz Voltage range : 10V~30V
	HDI	Digital input terminal /High-speed pulse input	Digital input terminal : same as DI1~DI4 and DI6-DI7 Pulse input frequency input : 0~50KHz Voltage range : 15V~30V
	Switch output	DO1	Open collector output
YCOM		DO1 Ground	Internally isolated from GND, 0V, COM
HDO		Open collector output /High-speed pulse output	Open collector output : same as DO1 High-speed pulse output : 0~50KHz COM Reference ground is COM
Relay 1	T1A/T1B/T1C	Relay 1 output	T1A-T1B : normal close T1A-T1C : normal open
Relay 2	T2A/T2B/T2C	Relay 2 output	T2A-T2B : normal close T2A-T2C : normal open

VFD580 control circuit wiring diagram

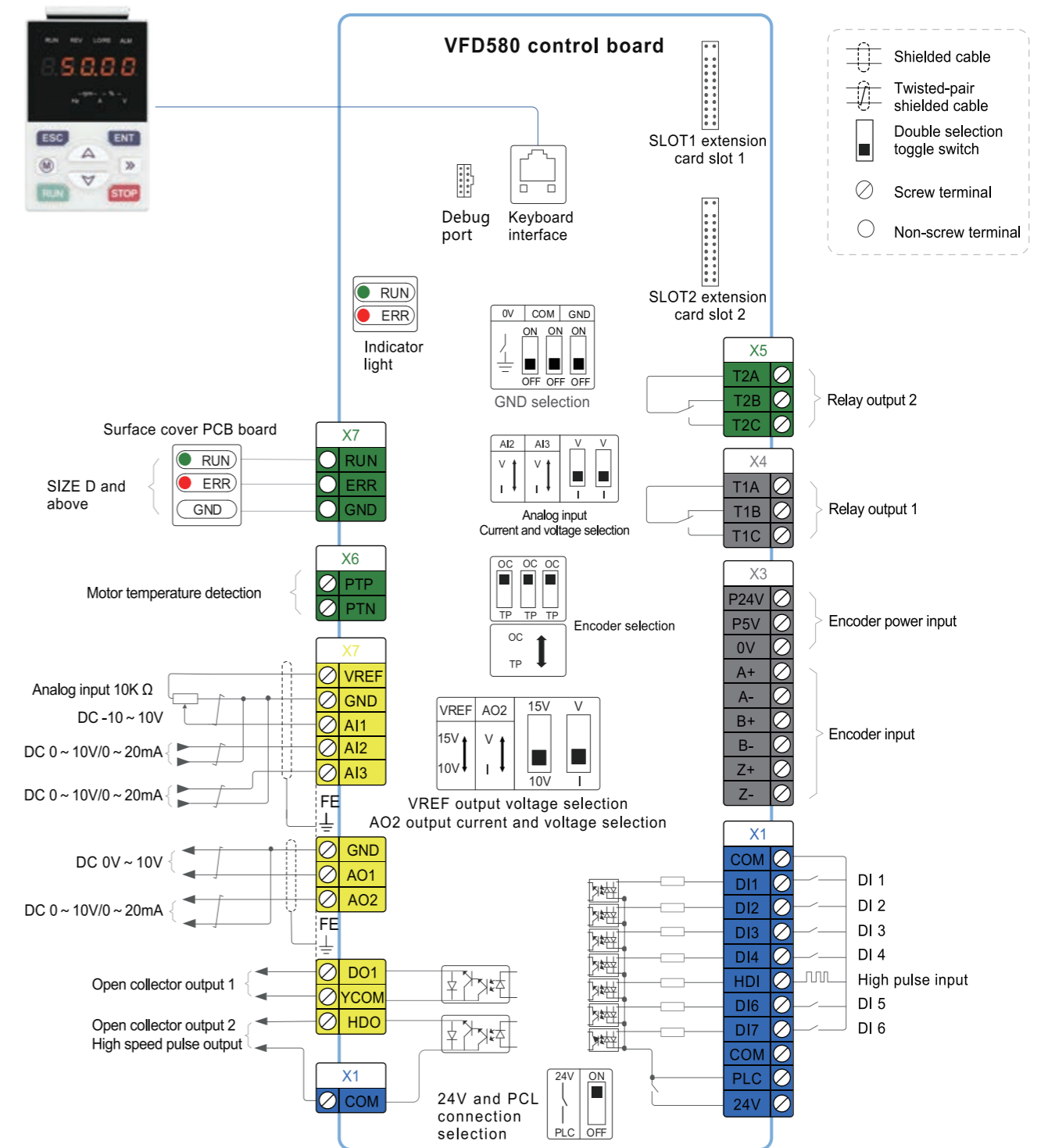

- Notice :**
- Please connect the shielding layer to the grounding terminal of the inverter, otherwise it will cause malfunction or malfunction of the inverter and the machine;
 - The FE terminal in the figure is the grounding terminal of the shielding wire on the grounding sheet metal part, and the specific position is shown in Figure 4-11 "FE";
 - The wiring diagram of the control circuit in the above figure represents a schematic representation. For specific wiring and instructions, please refer to the following instructions;
 - The above "X7" terminal wiring has been connected to the PCB board of the front cover, no wiring is required.

VFD586 control panel

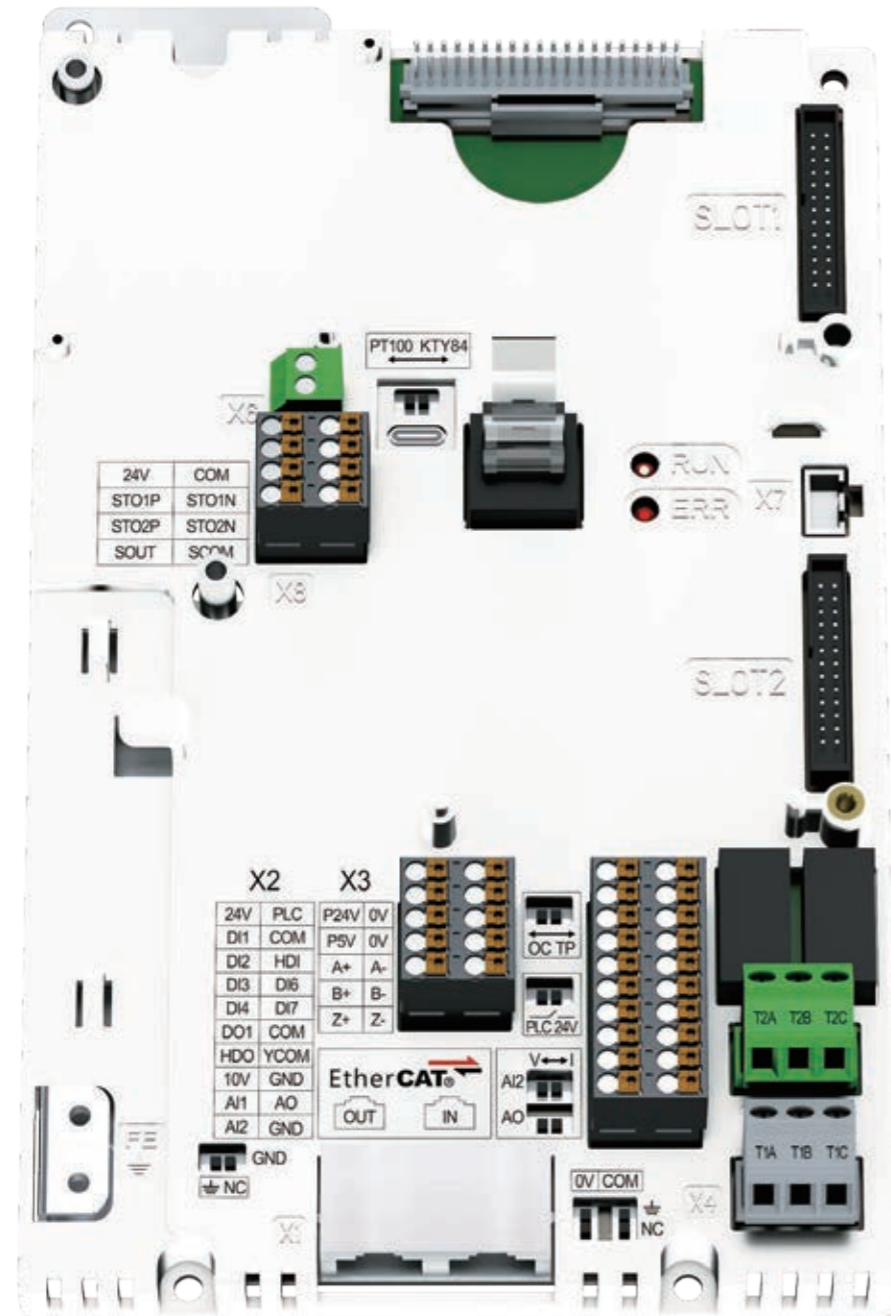

Definition of VFD586 control circuit terminals

Type	Terminal symbol	Terminal Name	Terminal function description
STO (Safe Torque Off) I/O	24V	STO power supply	24V±10%, internally isolated from GND and 0V
			Maximum output current: 200mA
			Provide 24V power to the outside, used as STO input and output power supply
	COM	STO Power reference ground	Internally isolated from GND and 0V
	STO1P	STO control signal 1 positive polarity input terminal	When the STO1 or STO2 input is OFF, the STO safety function is valid and the output is cut off
	STO1N	STO control signal 1 negative polarity input terminal	
	STO2P	STO control signal 2 positive polarity input terminal	
STO2N	STO control signal 2 negative polarity input terminal		
SOUT	STO output signal terminal	Output ON when STO1 or STO2 input OFF	
SCOM	STO output signal common terminal		
Analog input	10V	Input voltage	10V±3% Maximum output current 30mA, recommending external potentiometer resistance range: 1KΩ to 51KΩ.
	GND	Analog input ground	Internally isolated from COM, 0V
	AI1	Analog input 1	Only input voltage:-10V~10V : Impedance 20KΩ
	AI2	Analog input 2	Input voltage:0~10V : Impedance 20KΩ , Maximum input voltage
			I Input current:0~20mA : Impedance 500Ω , Maximum input current Through the jumper switch AI2 0 ~ 10V and 0 ~ 20mA analog input switch, the factory default voltage input.
	A0	Analog output	Output 0 ~ 10V: Impedance ≥10KΩ Output current:0~20mA : Impedance 200Ω~500Ω Switching between 0-10V and 0-20mA via AO. Factory default is voltage output.
GND	Analog ground	Internal isolation from COM and 0V	
Digital input terminal	+24V	+24V current	24V±10% , Internal isolation from GND Maximum output current : 200mA Provide 24V power externally, generally used as the operating power for DI/DO terminal and external sensor power. When the "24V/PLC" toggle switch is ON, +24V and PLC are connected
	PLC	Digital input terminal common	The factory default setting is connected PLC with +24V terminal for on-off input high and low level switch When using the external power input, it will disconnect the connector slip of PLC with the +24V
	COM	+24V ground	Internal isolation from GND and 0V
	DI1 ~ DI4 /DI6 ~ DI7	Digital input terminal 1-4 or 6-7	Optocoupler isolation, compatible with bipolar input Frequency range : 0~200Hz Voltage range : 10V~30V
	HDI	Digital input terminal /High-speed pulse input	Digital input terminal : same as DI1~DI4 and DI6-DI7 Pulse input frequency input : 0~50KHz Voltage range : 15V~30V
Digital output terminal	DO1	Open collector output	Optocoupler isolation Voltage range : 0V~28V Current range : 0mA ~50mA
	YCOM	DO1 Ground	Internally isolated from GND, 0V, COM
	HDO	Open collector output /High-speed pulse output	Open collector output : same as DO1 High-speed pulse output : 0~50KHz Reference ground is COM
Relay 1 output	T1A/ T1B/ T1C	Relay output	T1A-T1B: normal close T1A-T1C: normal open Contact capacity : AC 250V , 3A ; DC 30V , 1A
Relay 2 output	T2A/ T2B/ T2C		T2A-T2B : normal close T2A-T2C : normal open Contact capacity : AC 250V , 3A ; DC 30V , 1A

VFD586 control circuit wiring diagram

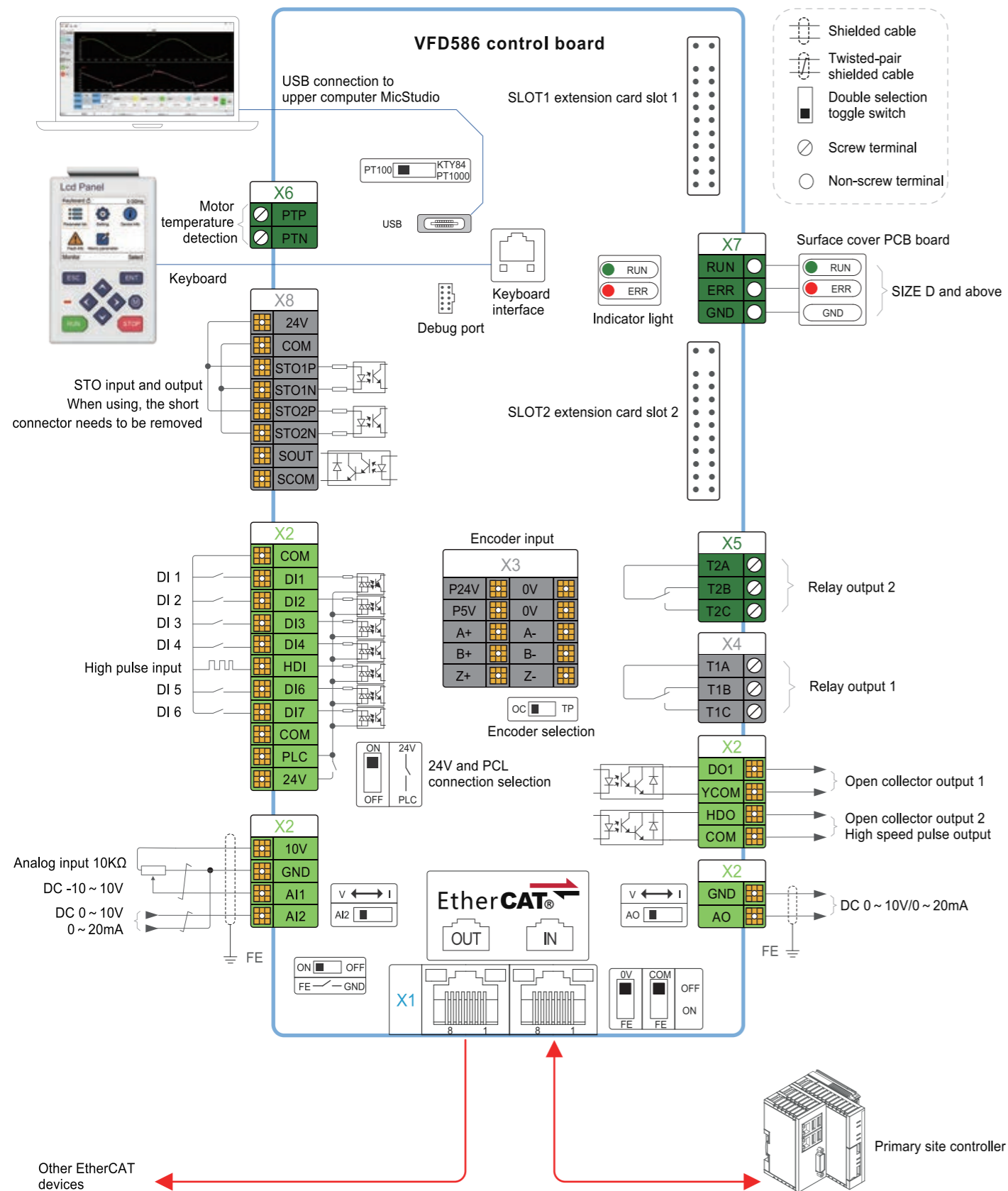

Optional accessories

Encoder interface card		
Name/Model	Picture	Description
Incremental encoder PG card Model : MT580-PG-ABZ2		The input signal can be a differential type or an open-collector type, which can be selected by a DIP switch; the frequency can be divided arbitrarily, and the output signal has two types: an open-collector type and a differential output type;
Fully closed-loop incremental PG card Model : MT580-PG-ABZD2		It is used in position fully closed loop applications. The PG card contains one incremental ABZ differential encoder feedback and one position pulse input, and also has an arbitrary frequency division output interface.
ABZUVW encoder PG card Model : MT580-PG-ABZUVW2		Used to match the ABZUVW type encoder, and has any frequency division output interface
Resolver PG Card Model : MT580-PG-RT1		Support 7Vrms, 10kHz excitation signal, support two transformation ratios of 0.5 and 0.286, with 1:1 pulse output.
Sincos encoder PG card Model : MT580-PG-SIN2		Support sine and cosine encoder detection, with CD signal detection function, and has any frequency division output interface.
Tamagawa serial protocol absolute value PG card Model : MT580-PG-ABS2		Support Tamagawa protocol absolute value encoder, and has any frequency division output interface.
SSI encoder PG card Model : MT580-PG-SSI2		Encoder that supports SSI/BISS communication protocol, and also has arbitrary frequency division output interface.

Communication card

Name/Model	Picture	Description
Communication card Model : MT580-COMM-485		It can simultaneously integrate 485 and CAN communication units, and support communication signals of both 485 and CAN. The interface is dual RJ45 Ethernet ports, with two interfaces having the same definition, which can be directly networked using network cables.
Communication card Model : MT580-COMM-PN		MT580-COMM-PN communication card is a ProfiNet communication card with dual network ports.

Keyboard

LED display Model : MTBOP1		Used for parameter setting, status monitoring and operation control.
Dual-display Model : MTBOP2		It has a digital potentiometer for setting parameters, status monitoring, and operation control; the first line of LED digital display is used for monitoring and auxiliary display; the second line is used for switching monitoring/menu mode, function code selection, and parameter editing/viewing.
LCD display Model : MTSOP1		It has the functions of parameter setting, backup, copy, macro editing, status monitoring, start-stop control, fault query, program upgrade, etc.

Appearance and installation dimensions

Models within SIZE C

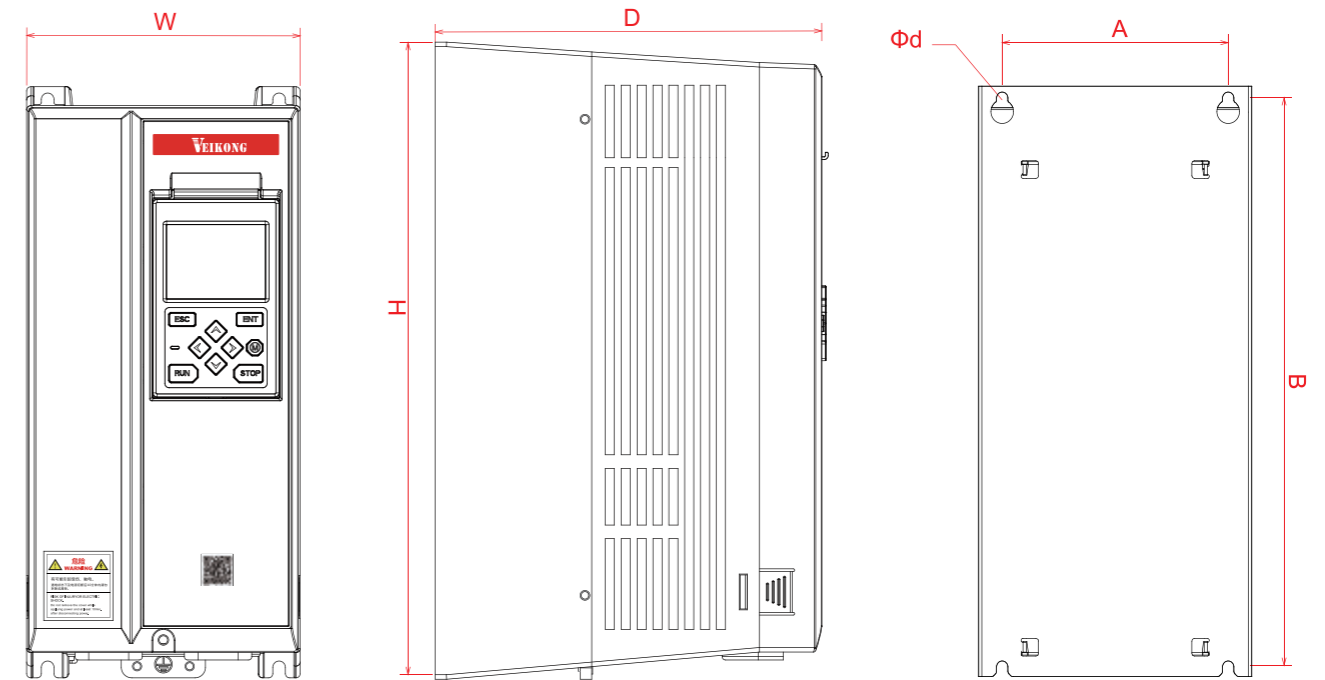

SIZE C and above models

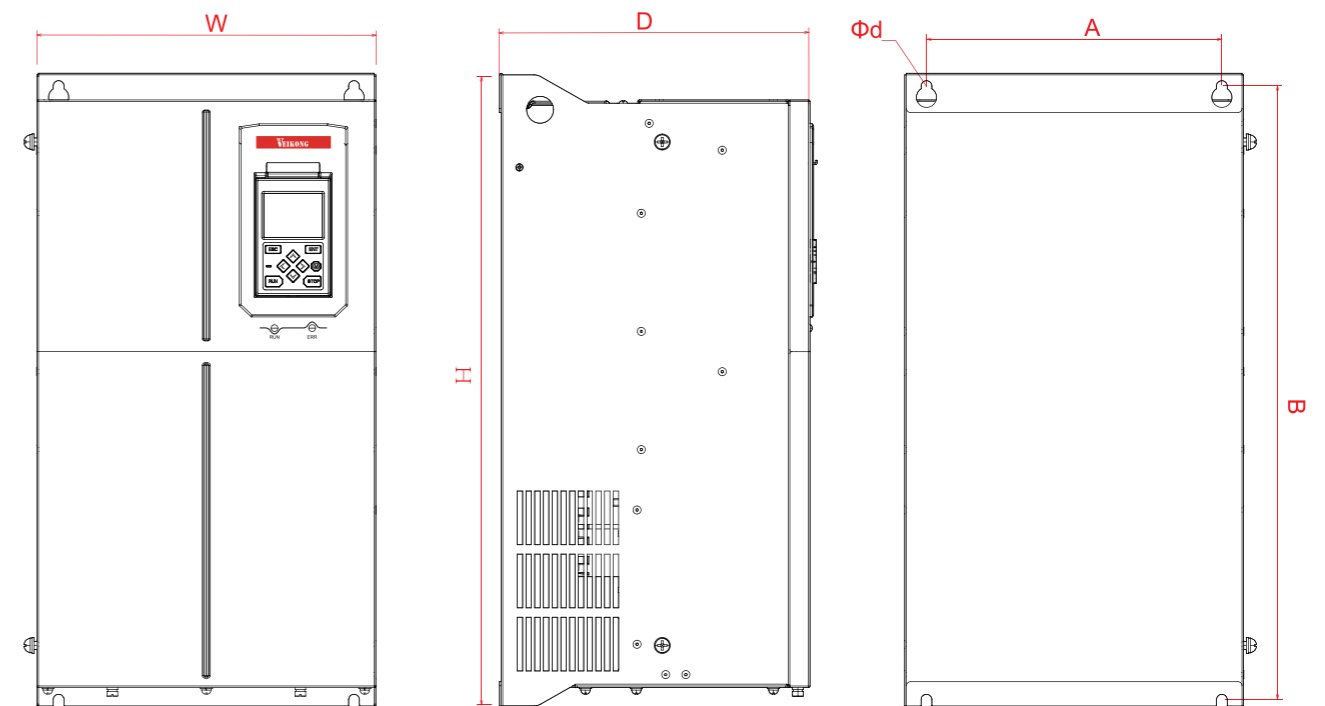

Models within SIZE H

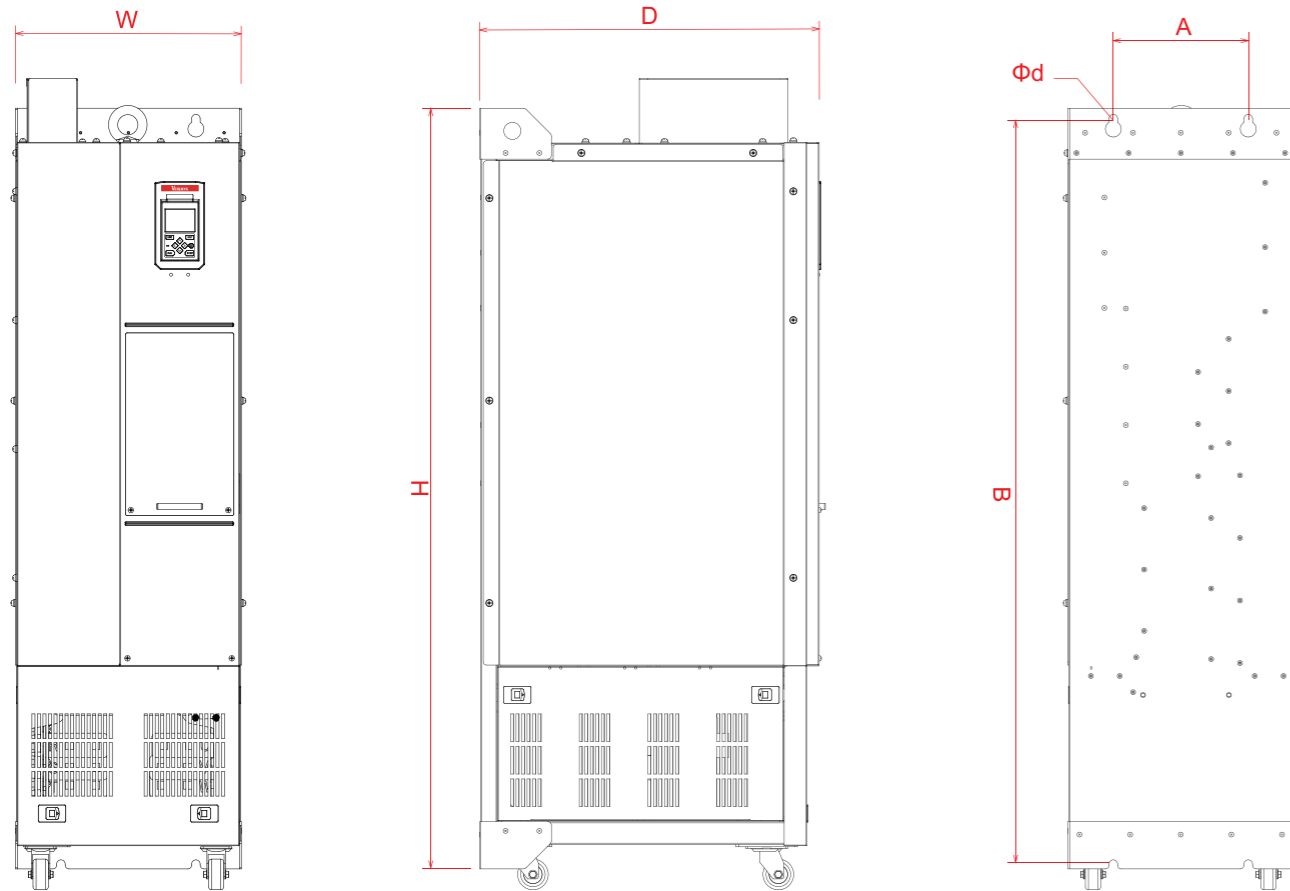

Number	Model	Appearance and installation dimensions (mm)						
		A	B	H	W	D	ød	Mounting screw
Three phase : 400V , 50/60Hz								
SIZE A	VFD580/586-2R2-T4B	110	270	281	130	173	ø6.0	M5
	VFD580/586-4R0-T4B							
	VFD580/586-5R5-T4B							
SIZE B	VFD580/586-7R5-T4B	120	290	301	145	193	ø6.0	M5
	VFD580/586-011-T4B							
SIZE C	VFD580/586-015-T4B	145	362	376	200	198	ø6.5	M5
	VFD580/586-018-T4B							
	VFD580/586-022-T4B							
SIZE D	VFD580/586-030-T4B	220	457	470	252	234	ø8.0	M6
	VFD580/586-037-T4B							
SIZE E	VFD580/586-045-T4 (B)	200	550	573	280	303	ø10	M8
	VFD580/586-055-T4 (B)							
SIZE F	VFD580/586-075-T4 (B)	220	672	689	295	311	ø10	M8
	VFD580/586-090-T4 (B)							
SIZE G	VFD580/586-110-T4	270	872	892	360	342	ø11	M10
	VFD580/586-132-T4							
SIZE H	VFD580/586-160-T4	330	975	1000	420	362	ø11	M10
SIZE I	VFD580/586-200-T4	220	1215	1240	368	555	ø14	M12
	VFD580/586-220-T4							
	VFD580/586-250-T4							
SIZE J	VFD580/586-280-T4	230	1456	1490	368	575	ø14	M12
	VFD580/586-315-T4							
Single phase/Three phase : 220V , 50/60Hz								
SIZE A	VFD580/586-0R7-S2B (T2B)	110	270	281	130	173	ø6.0	M5
	VFD580/586-1R5-S2B (T2B)							
	VFD580/586-2R2-S2B (T2B)							
SIZE B	VFD580/586-4R0-S2B (T2B)	120	290	301	145	193	ø6.0	M5
	VFD580/586-5R5-S2B (T2B)							
SIZE C	VFD580/586-7R5-S2B (T2B)	145	362	376	200	198	ø6.5	M5
	VFD580/586-011-S2B (T2B)							
SIZE D	VFD580/586-015-S2B (T2B)	220	457	470	252	234	ø8.0	M6
	VFD580/586-018-S2B (T2B)							

Application scheme of roving machine

Equipment introduction

The roving frame is a machine that produces coarse yarn from combed or carded fibers, made of pure cotton, synthetic or blended fibers. The fibers are twisted together and wound onto a package to meet the customer's needs for subsequent fine yarn production.

In the entire textile industry process, the roving frame is the subsequent process to the cotton carding and drawing machine and the preceding process to the spinning machine. Its internal structure can be roughly divided into four parts: rollers, flyer wings, winding, and lifting, which are driven by four drivers.

During the process of twisting the fiber into the desired package, the appropriate tension must be maintained, requiring high synchronicity and fast response speed when starting or stopping the four drivers.

Advantage

1

CAN Communication Position Synchronization

The CAN communication position synchronization is adopted among the four drivers, the acceleration, deceleration and speed stabilization are high precision, the speed consistency is good, and the tension is stable and does not fluctuate.

2

Power failure stop logic

Common DC bus design, built-in power failure stop logic, automatic stop when instantaneous power failure, stable and continuous yarn.

3

One-key debugging

The software has built-in application macro parameters, and four drivers correspond to four macro instructions, which can be set with one key, eliminating the need for complicated debugging steps.



System scheme composition

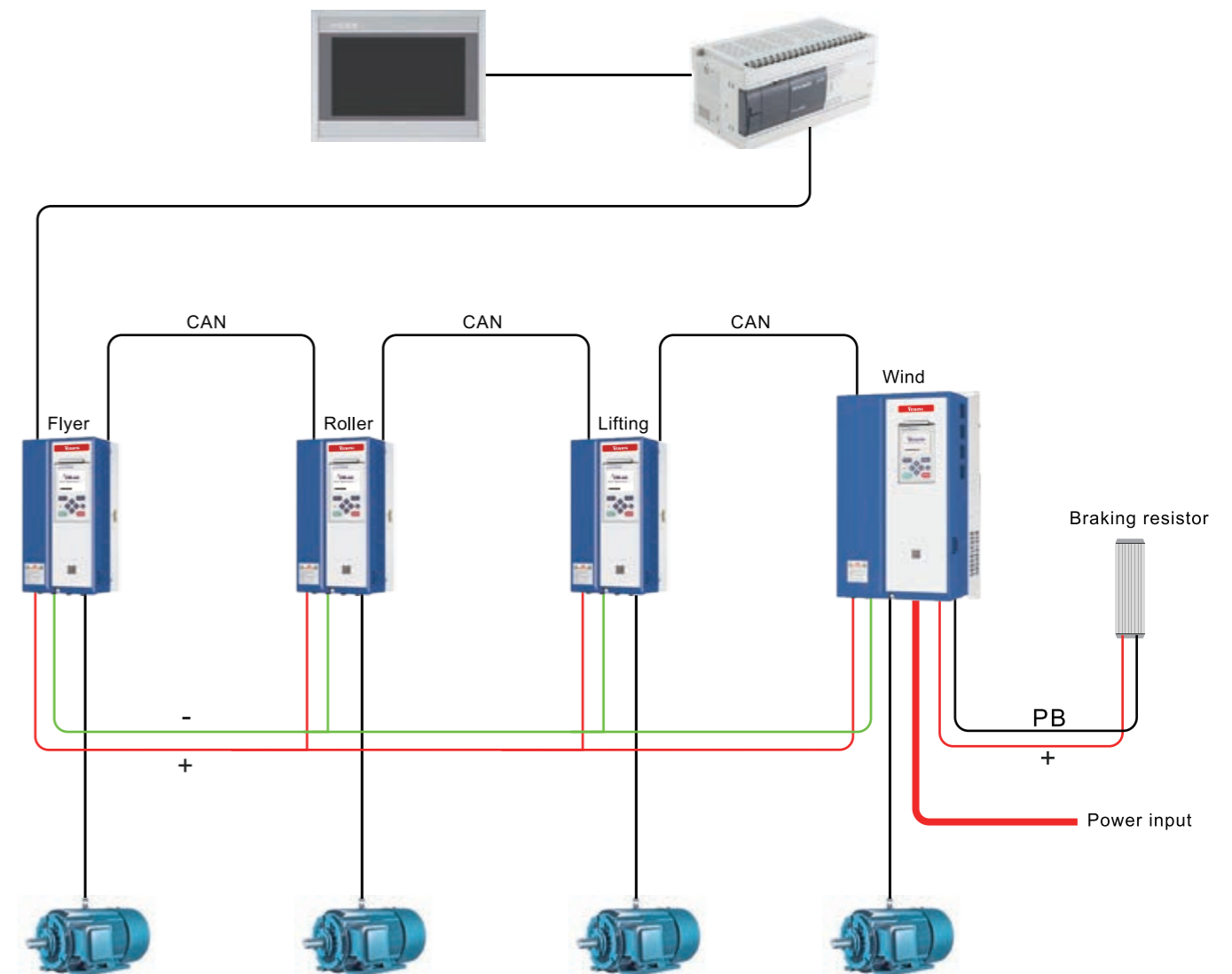

Application plan for warping machine

Equipment introduction

The warping machine belongs to the textile equipment. It draws a certain number of warp yarns from the yarn cone, which are then formed into a warp beam (the width of which is set according to the width of the fabric needed for the weaving machine), making the warp yarn have uniform tension, parallel and tightly wound on the beam.

In the entire process of the textile industry, the warping machine is a post-process of the creel and doubling machine and a pre-process of the weaving machine. The warping machine is divided into four parts: the tail frame (one on each side), the drawing, the thread guide roller, and the warping head.

The working requirements of the warping machines call for appropriate tension on the warp yarn and consistent tension across its entire width. Therefore, the precision of synchronization between the drives needs to be high, and the start and stop actions should be quick and stable.

Advantage

1

Dynamic fast response

The servo motor adopts a 23-bit absolute value encoder, with higher speed and position control bandwidth, ensuring rapid and smooth equipment start and stop, and stable tension on the yarn during the start and stop process without any changes.

2

Full pulse position synchronization

All five drives adopt full pulse position control mode, with high stability and accuracy, and good response and tracking performance. This ensures consistent tension and drawing ratio of the entire yarn, and reduces the rate of yarn breakages during subsequent processing.

3

One-click debugging

The software has built-in application macro parameters that can be easily set with one click, eliminating the need for complex debugging steps.



System scheme composition

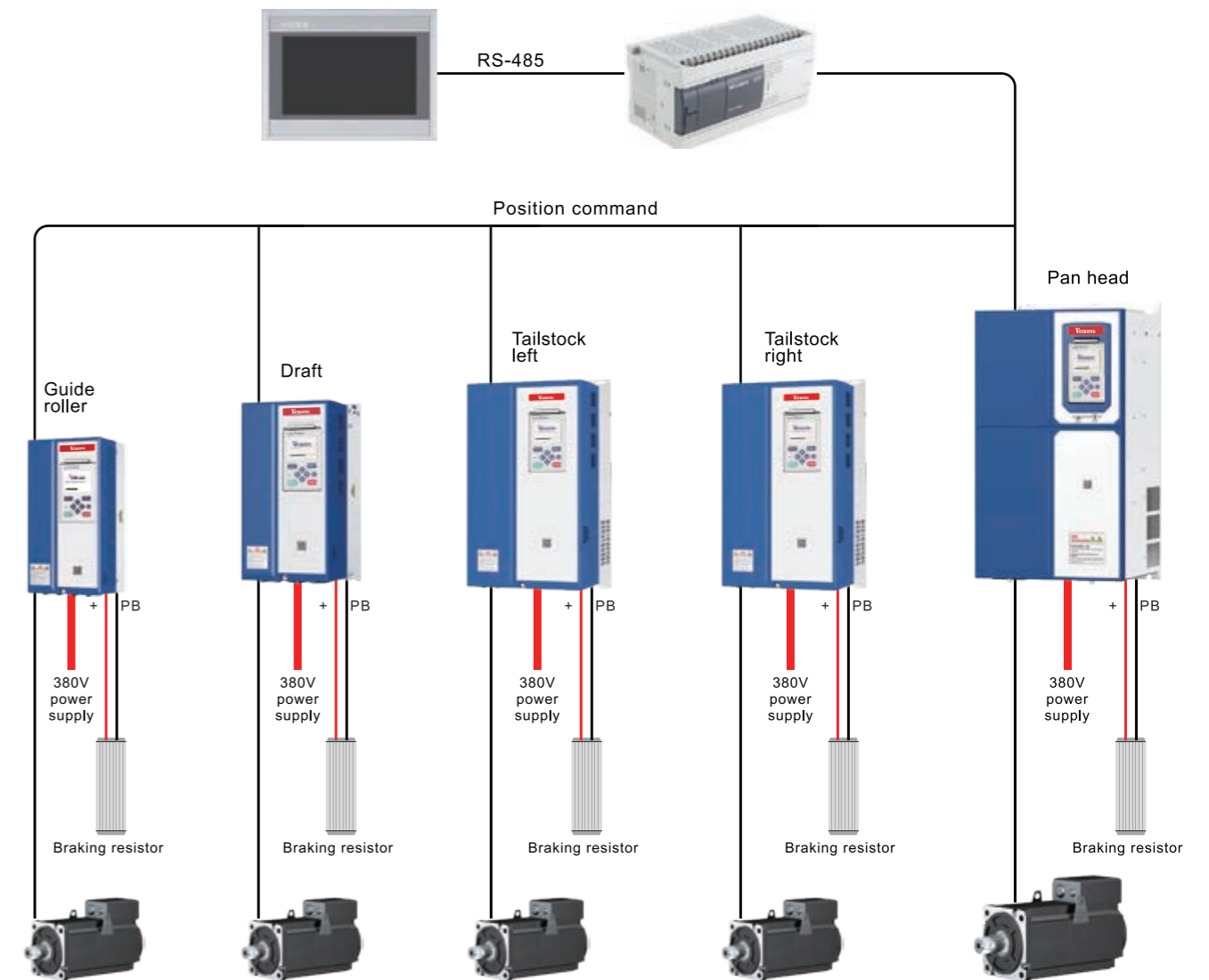



Application scheme of servo screw press

Equipment introduction

Screw Press refers to a type of mechanical press that generates pressure by rotating a group of above external bolts and internal bolts within a frame.

The flywheel, sleeve shaft, and nut of the motor-driven spiral press frequently rotate in both directions, and the nut drives the screw and slider to move up and down, thus generating impact force.

Compared with traditional spiral presses, the electric spiral press with direct-driven flywheel has a compact structure and fewer transmission links. However, due to frequent reversing, the driver needs to have a higher performance to meet the requirements of quick reversal and accurate control of up and down reciprocating distance.

Advantage

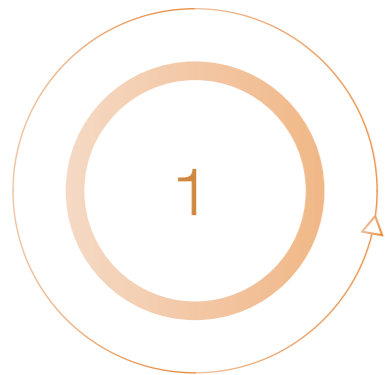

Big torque in low frequency

With high low-frequency torque, excellent dynamic characteristics, and strong overload capacity, the rapid and smooth reversal is ensured with the support of strong torque and overload capacity.

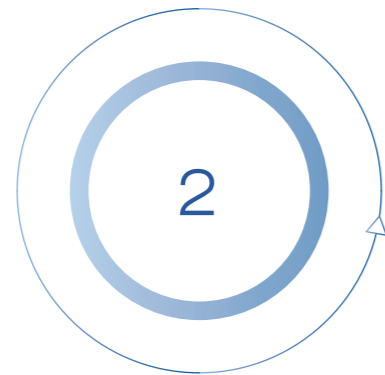

Anti-slip function

Built-in anti-slip logic, online detection of operating status, real-time and rapid response adjustment to prevent mechanical slipping.

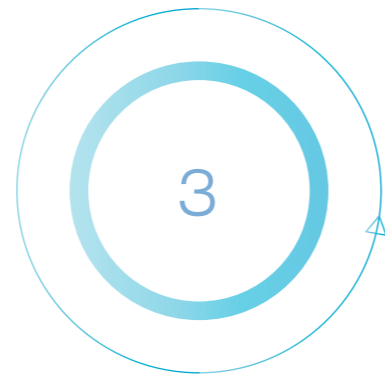

Built-in craft process

The entire craft process control action is built-in the driver to complete. Simply set the speed, return height and number of hits for each gear, and the driver will calculate and complete the action on its own, eliminating the need for complex control logic of PLC.



System scheme composition

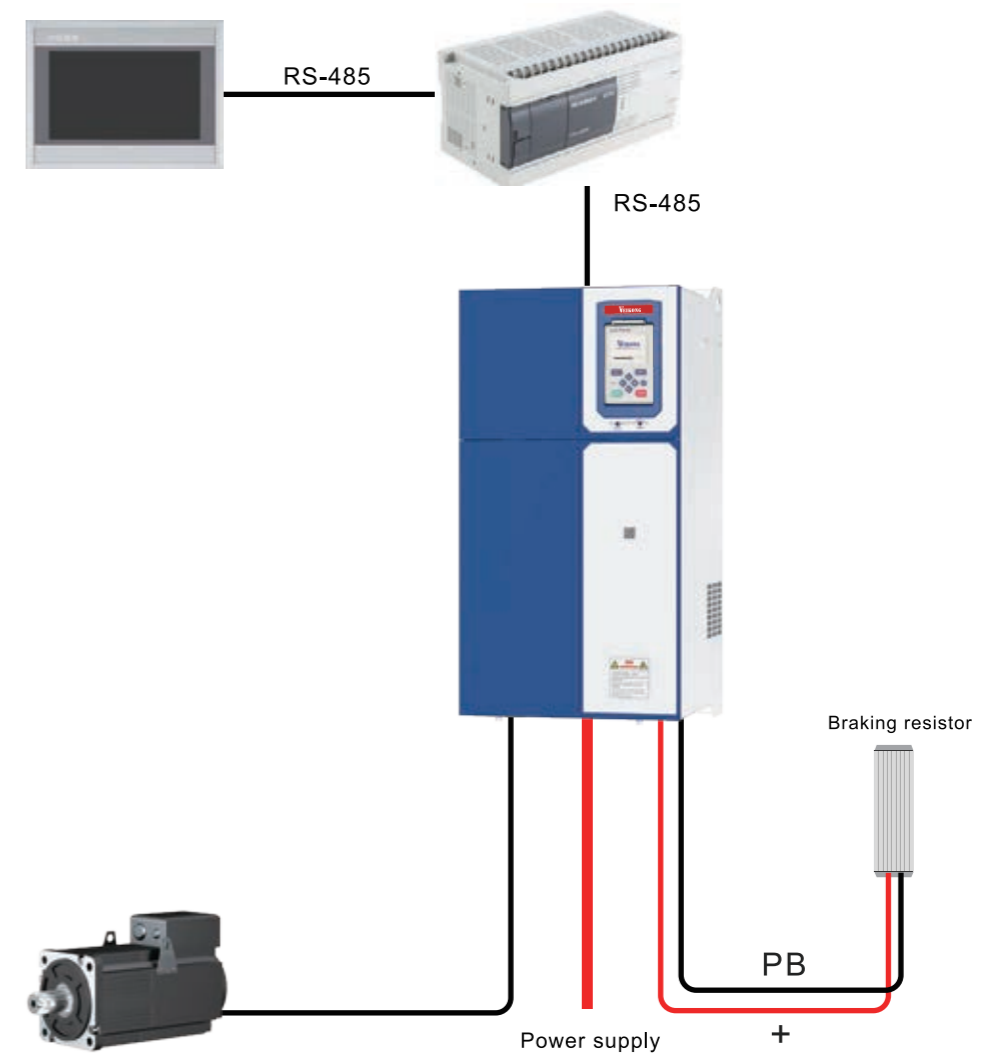

Application plan for high speed electric spindle machine tool

Equipment introduction

Machine tool refers to the machine that manufactures other machines, also known as working mother machine or tool machine, commonly referred to as machine tool.

High-speed electric spindle machine tool is a precision and efficient machine tool evolved from ordinary machine tools under continuous optimization and upgrading. It requires the driver to have higher torque and precision control to meet the processing requirements of workpieces.

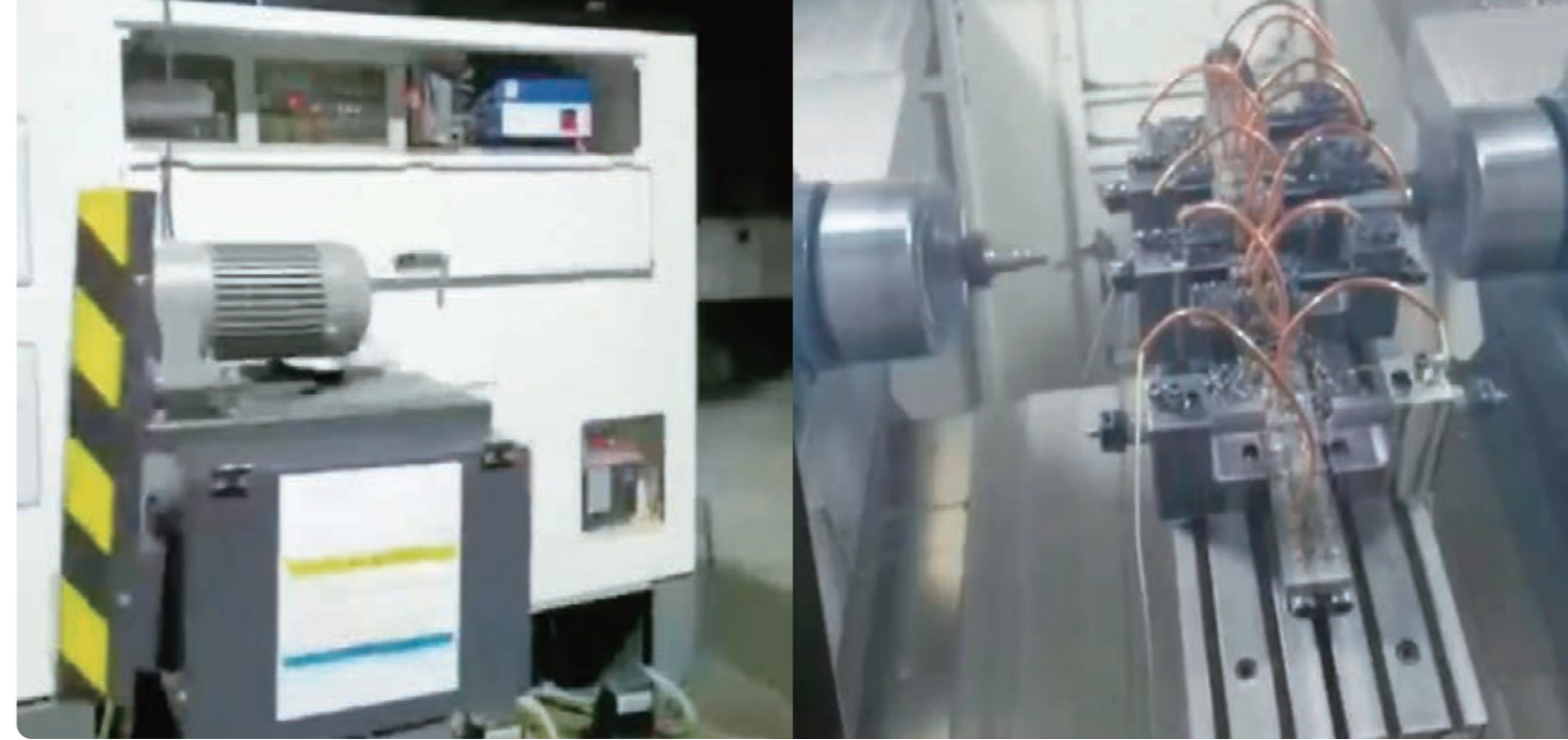

Advantage

1

Fast

Relying on the advanced algorithm of VFD580 servo drive, it can realize zero-second acceleration and deceleration.

2

Accurate

Steady speed accuracy $\leq 0.5\text{rpm}$; spindle orientation and position indexing accuracy $\leq \pm 0.01\text{mm}$.

3

Stable

Strong rigidity, fast and stable start and stop, no vibration; zero speed stability and no vibration.

4

High

The highest frequency can reach 2500HZ

5

Large

Large low-frequency torque output, stable operation at 0.01HZ, strong overload capacity, 200% overload current can still run stably for 10S.

6

Broad

The algorithm has a wide adaptability and can drive synchronous/asynchronous high-speed electrical spindles; it supports analog pulse, EtherCAT bus; and supports incremental encoder, sine-cosine encoder, 17/23-bit absolute encoder, SSI/BISS encoder.

System scheme composition

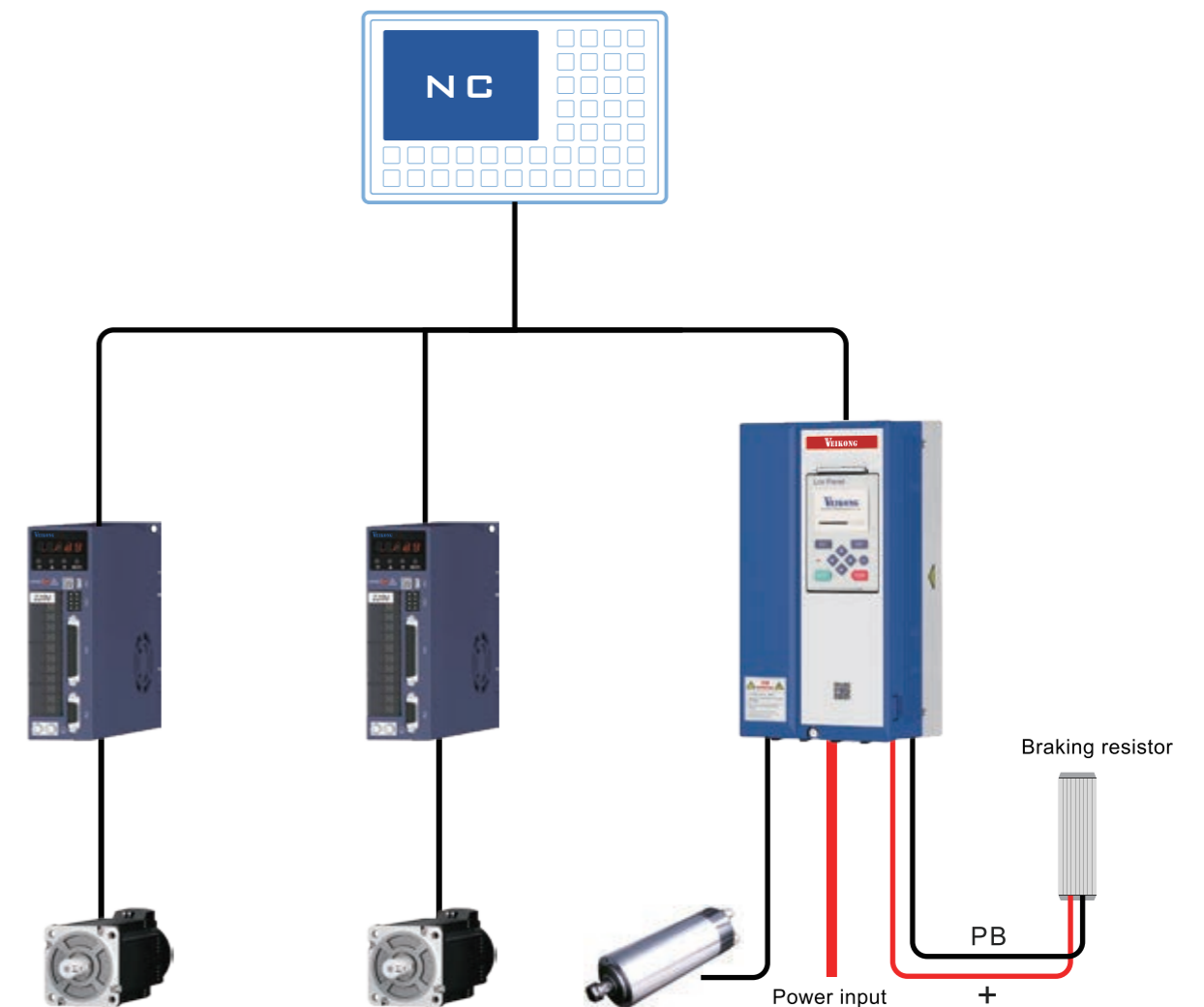

Application plan for friction welding machine

Equipment introduction

Friction welding refers to the equipment that uses the heat generated by the friction between the end faces of the workpiece to make it reach a plastic state, and then upsets to complete the welding.

Friction welding machines usually fix the two ends of the workpiece to be welded in the rotating and moving fixtures respectively. After the workpiece is clamped, the moving fixture on the slide moves with the slide to the rotating end. After moving a distance, the rotating workpiece starts to rotate, and frictional heating welding begins after the workpiece contacts.

Due to the need to control the phase of rotating components relative to the other side during the brake and stopping phase, and to complete welding before the components cool, the driver must have sufficient overload capacity, fast instruction response speed, fast positioning speed, and precise positioning accuracy.

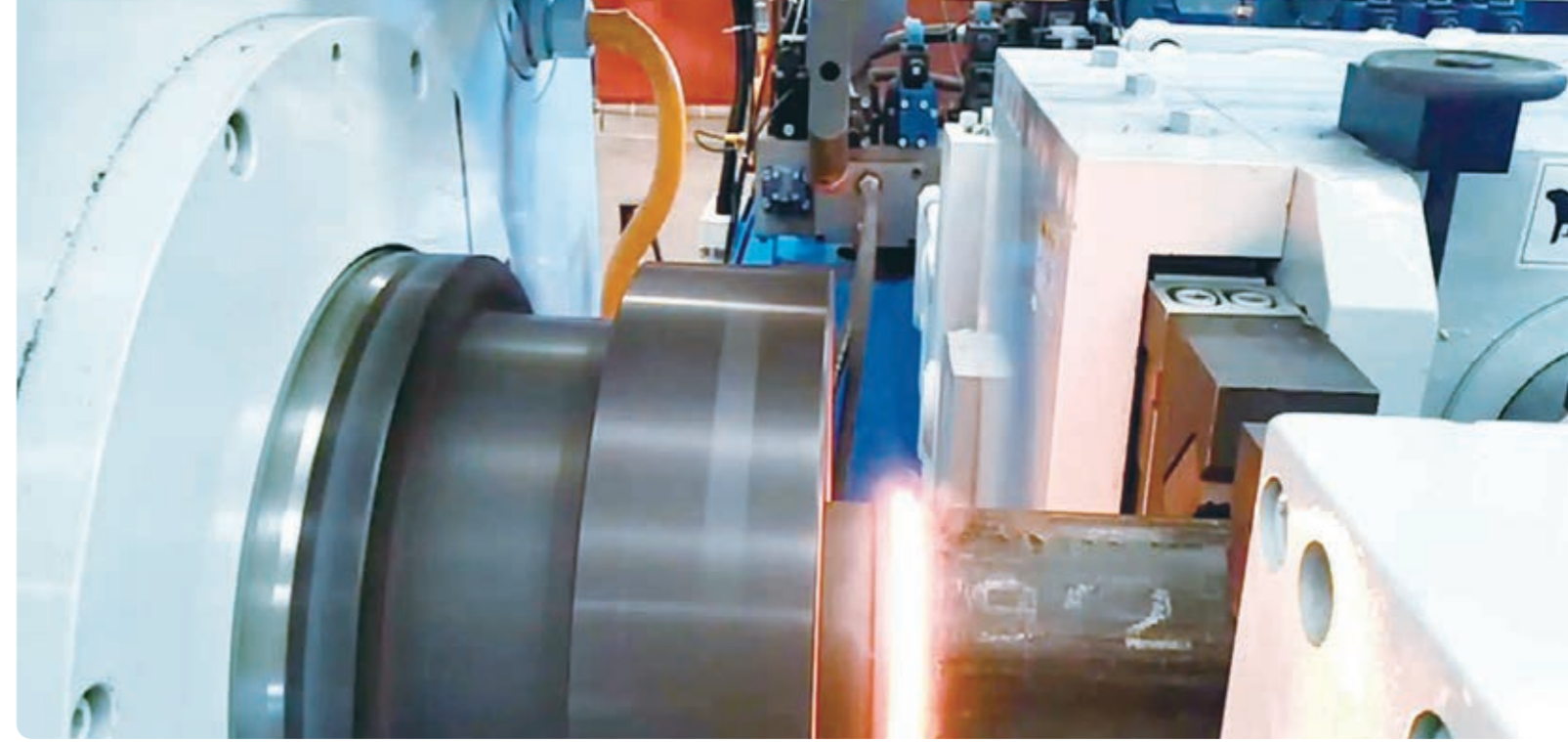

Advantage

1

Adaptive positioning speed

The positioning speed in the static state is set according to the actual situation, and the positioning speed in the running state is positioned according to the running speed.

2

Fast and accurate positioning

The positioning time is 0.1 second and can accurately stop at the set position.

3

Low frequency high torque

With the support of high low-frequency torque, excellent dynamic characteristics, strong overload capacity, and high torque and strong overload capacity, the welding and positioning process can run smoothly.

System scheme composition

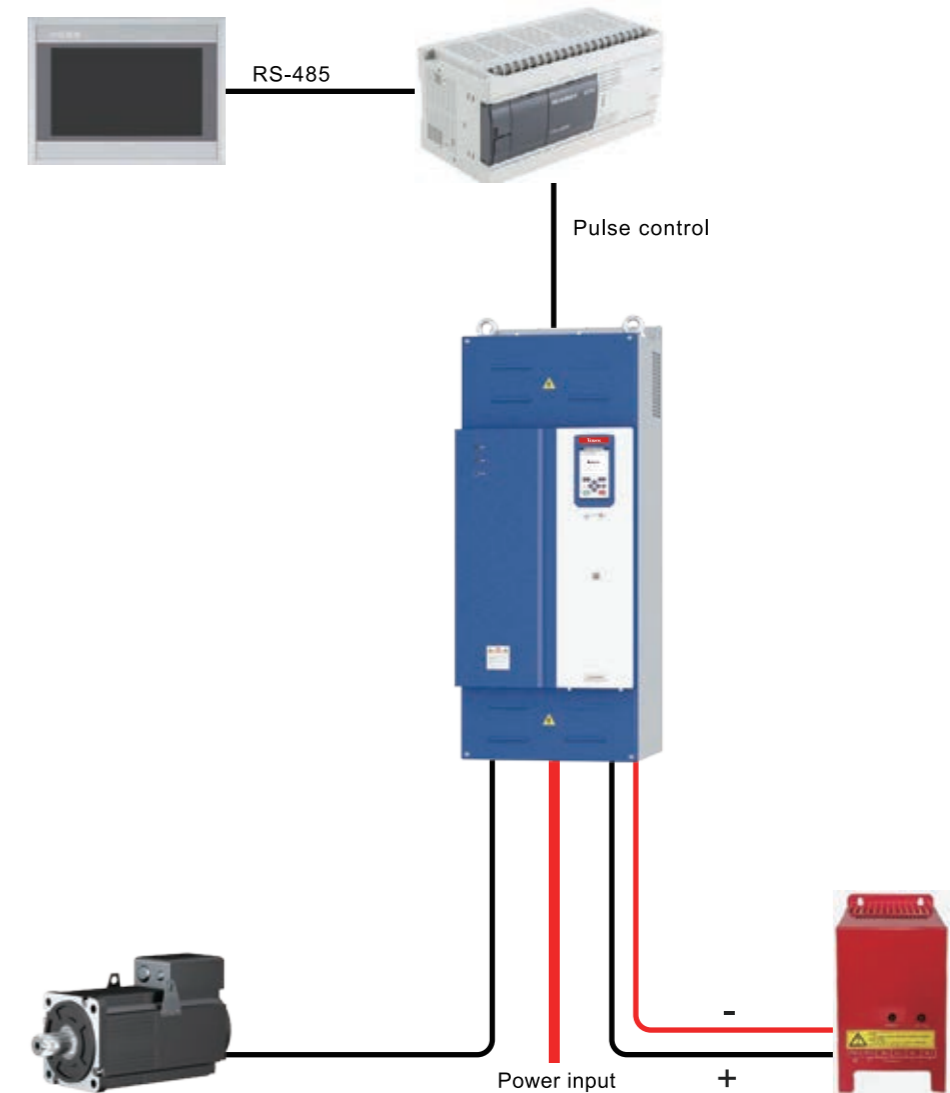

Flying shear application plan

Equipment introduction

Flying shears, that is, shearing machines that transversely shear the rolling stock in operation. It is a processing equipment that can quickly cut iron plates, steel pipes, and paper rolls. It is a cutting-to-length cutting machine for high-speed wire rods and rebars in the metallurgical steel rolling industry.

Flying shears are installed on the rolling operation line to cut the head and tail of the rolling piece horizontally or cut it into a fixed length. During the movement of the rolling piece, the cutting blade moves relatively to cut off the rolling piece.

Flying shears to length should ensure good cutting quality - accurate length, neat cutting surface and wide adjustment range of length, and at the same time must have a certain cutting speed, which requires a high control performance of the drive.

Advantage

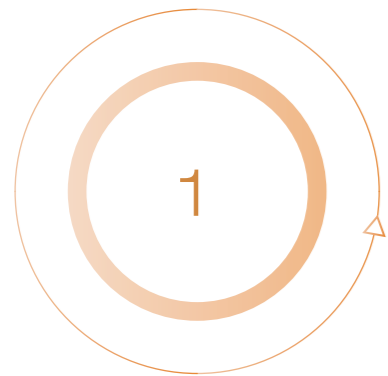

High integration

The VFD586 has built-in electronic cam function, which helps customers reduce control system costs; it is pulse and bus compatible, with flexible control system configuration.

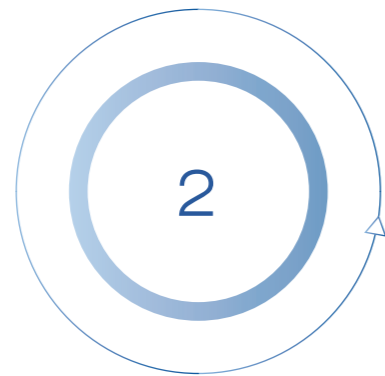

High precision

The cutting precision error is less than 0.1mm, with almost no error.

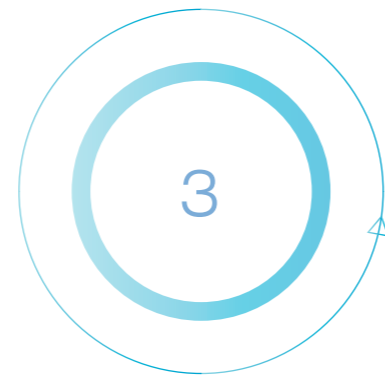

Strong overload capacity

200% overload can still run for 10 seconds, and cutting thicker materials can still maintain precision and efficient operation.

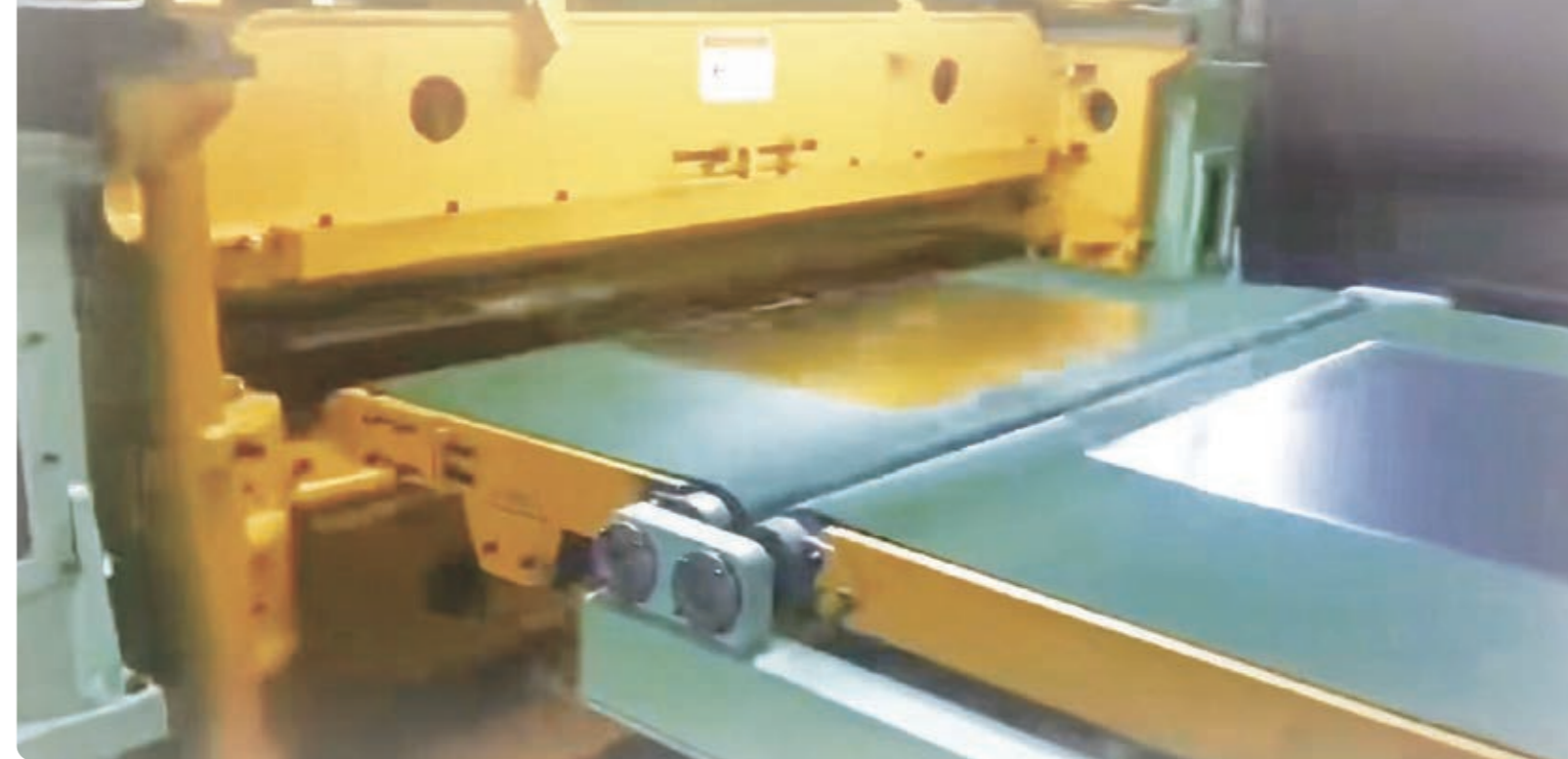

System scheme composition

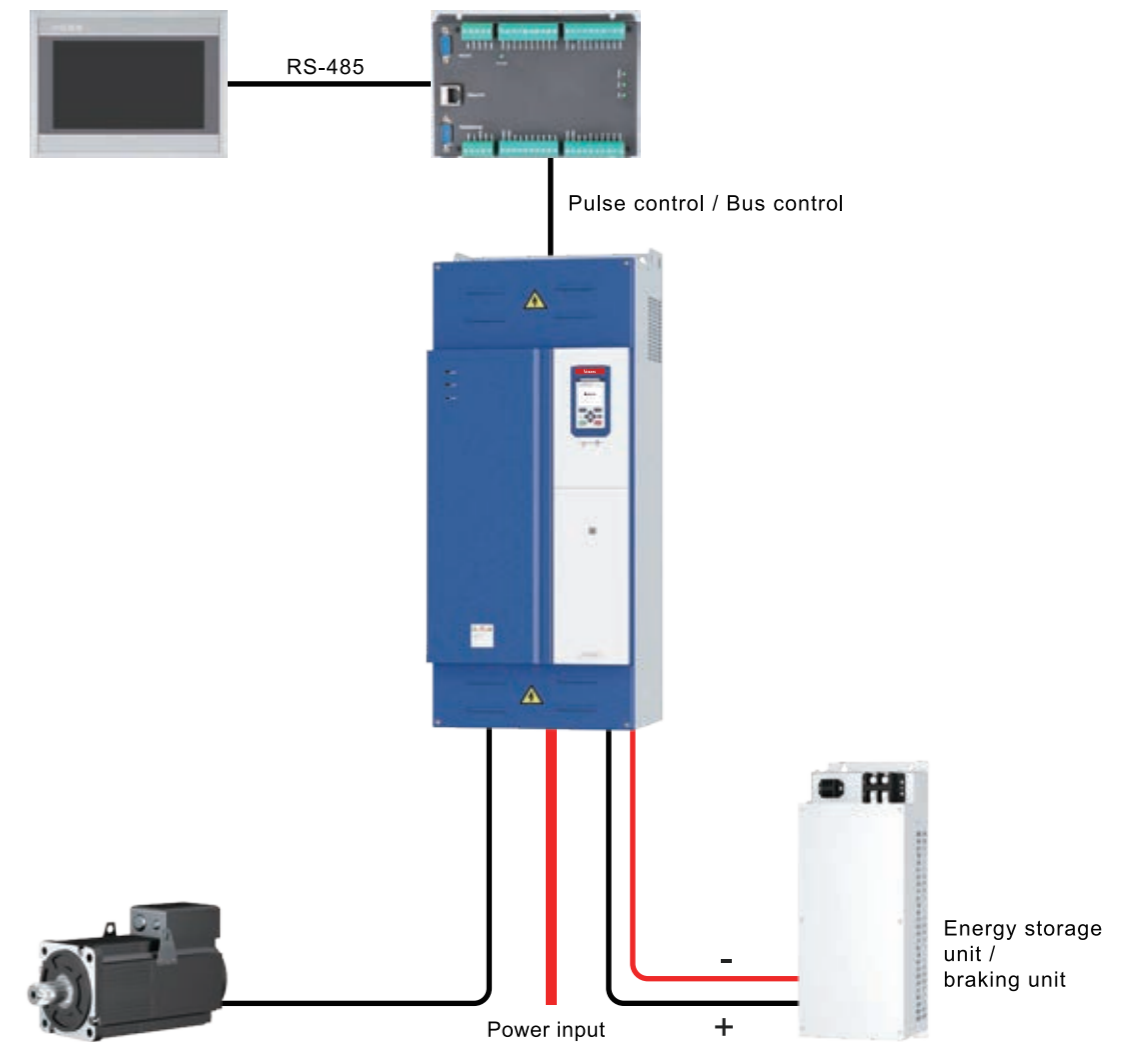

Wide applications

Textile industry

Reduce yarn breakage and improve production efficiency; Unique power outage shutdown function, no yarn breakage during power outage; Large heat design, supports wall installation, no reduction in performance at 50°C ambient temperature.



Hydraulic-driven equipment

Fast response speed, high starting torque, and good injection molding effect; Energy-saving rate can reach up to 25%~70%; Independent air duct design, rear components and fans are easy to disassemble, facilitating maintenance.



Machine tool industry

Support high-frequency output; Spindle open-loop control: excellent PWM modulation method, with low speed noise; High cutting force at low frequency, short acceleration and deceleration time, and higher processing efficiency.



Printing and packaging industry

High-performance vector control and torque control are used to achieve constant linear speed and tension control; Suitable for slitting machines, coating machines, printing machines, dyeing machines, papermaking machines, cable equipment, etc. Sensorless vector control can be widely used in place of torque motors.



Hoisting equipment

Quick response speed, high starting torque; Reliable brake timing control, professional lifting control function; Widely applicable to lifting equipment in various industries such as ports, construction, mining, metallurgy, and factories.



Metal processing industry

Without sensors, vector control torque has high precision, eliminating the need for encoders; Master-slave torque allocation is simple and efficient; Stable operation without downtime.



Oilfield

Special control functions for oil fields; Higher energy-saving effect, less harmonics and reactive current; Unique anti-freezing function to ensure reliable intermittent work of the pump in winter.



After sale service system

1. Veikong offers an 18-month quality guarantee. We will take responsibility for any problems caused during this period. As long as customers provide us with machine error reports, we will provide free repair parts for them.
2. If you have any problems during use, please contact your sales representative in a timely manner. Meanwhile, we will build a professional technical team online to solve complex application issues for you.

Veikong, your trusted supplier !